

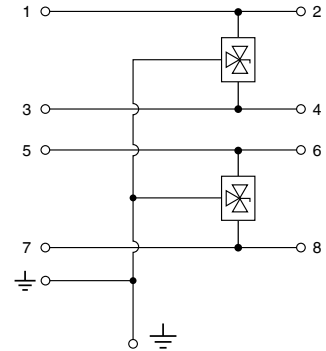

IEC/EN Category: C1/C3
 Surge Discharge Ratings: I_n : 250 A
 Voltages: 30V DC
 Frequency Range: 30 MHz
 Housing: Modular Design
 Compliance: IEC/EN 61643-21
 UL 497B 4th Edition

Configuration:



Technical Data

SLL-4 Series

30

Electrical

Lines Protected		2 (4 Conductors)
Nominal Operating Voltage (DC)	U_n	30V
Maximum Continuous Operating Voltage (DC)	U_c	33V
Rated Load Current at 25°C	I_L	10 A
C1 Nominal Discharge Current (8/20 μs)	I_n	250 A
Residual Voltage at 5 kA (8/20 μs)	(Line-Line) U_{res}	< 80V
Rated Spark Overvoltage	(Line-Line)	36-44V
	(Line-Ground)	36-44V
Response Time Overvoltage Protection	(Line-Line) t_A	< 1 ns
	(Line-Ground)	< 1 ns
Insulation Resistance of the Protection	(Line-Line) R_{iso}	≥ 33 MΩ
	(Line-Ground)	≥ 33 MΩ
Serial Resistance per Path	R	0.1 Ω
Transverse Capacitance	(Line-Line) C	50 pF
	(Line-Line)	50 pF
Cut-off Frequency	f_G	30 MHz

Mechanical

Temperature Range		-40 °F to +176 °F [-40 °C to +80 °C]
Terminal Cross Section Multi-strand (max.)		12 AWG [4 mm ² , 2.5 mm ² Q Version]
Terminal Screw Torque		4.5 lbf-in [0.5 Nm]
Degree of Protection IEC/EN 60529		IP 20 (built-in)
Housing Material		Thermoplastic; Grey; Extinguishing Degree V-0
Mounting IEC/EN 60715		35mm DIN Rail

Order Information

Order Code		30
SLL-4-xx		7082.92
SLL-4-xxQ (Quick Connect Terminals)		7085.27
SLL-4-xxM (module)		7082.93

RayDat SLL-4 Series

Internal Configuration

Legend
 DB Diode Block
 PG Protective Grounding

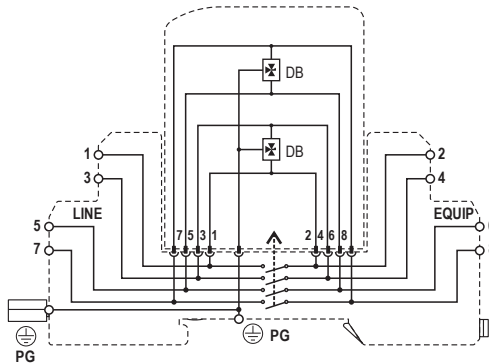

Dimensions & Packaging

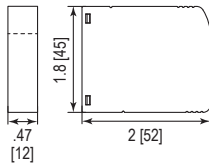
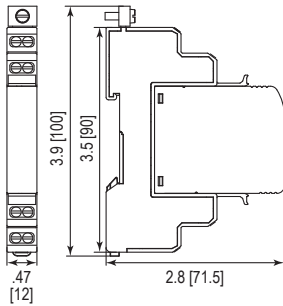

SLL-4 Series	30
Dimensions	
Weight per Unit	1.97 oz [56g]
Dimensions DIN 43880	2/3 TE
Packaging Dimensions (Single Unit)	3.4 x .59 x 4" [87 x 15 x 102 mm]
Minimum Package Quantity	15 pieces

SLL-4-xxM Series	30
Dimensions	
Weight per Unit	.77 oz [22g]
Packaging Dimensions (Single Unit)	3.4 x .59 x 4" [87 x 15 x 102 mm]
Minimum Package Quantity	15 pieces

Quick Connect Terminals

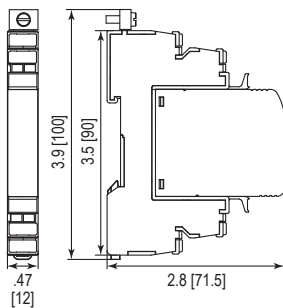

SLL-4-xxQ Series	30
Dimensions	
Weight per Unit	2.04 oz [58g]
Dimensions DIN 43880	2/3 TE
Packaging Dimensions (Single Unit)	3.4 x .59 x 4" [87 x 15 x 102 mm]
Minimum Package Quantity	15 pieces

inches
[mm]

Information contained in this document is subject to change at any time without notice.



www.raycap.com

© 2020 Raycap All rights reserved.
 G29-00-697 201120