

A night cityscape with light trails and digital lines. The background shows a city skyline at night with various skyscrapers and buildings illuminated. Overlaid on the scene are numerous vertical and diagonal lines of light in shades of blue, purple, and pink, creating a digital or data-like atmosphere. The lines vary in thickness and brightness, some appearing as thin streaks and others as thicker, more prominent beams. The overall effect is a blend of urban architecture and modern technology.

Raycap

Surge Protection for
Data & Signal Line Systems

2021
CATALOG

About Raycap



Raycap was founded in 1987 with a vision of creating and providing solutions that protect the world's infrastructure. From telecommunications to new and traditional energy networks, and from transportation systems to industrial applications of all types, Raycap is there with solutions to ensure equipment uptime in spite of harsh electrical environments. The company strives to keep its customers' sophisticated, mission-critical equipment running seamlessly and continuously, and is driven to make ongoing advancements in its surge protection technologies and product offerings.



Table of Contents

	RayDat Modular Features	2
	Icons Description	5
	Selection Guide	6
ANALOGUE SYSTEMS		
	RayDat SL Series	21
	RayDat SLH-2, RayDat SLH-4 Series	22-24
	RayDat SSH-3 Series	26
	RayDat SLL-4 Series	28
	RayDat SUI-4 Series	30
	RayDat SP Series	33
	RayDat SPH-2, RayDat SPH-4 Series	34-36
	RayDat SPI-2, RayDat SPI-4 Series	38-40
	RayDat SRH Series	43
	RayDat SRH-2 Series	44
	RayDat SRH-2L (LED) Series	46
	RayDat SRH-2L Accessories	48
	RayDat Ex Protection	49
	RayDat Ex-2 Series	50
	RayDat PLP Ex Series	52
DIGITAL SYSTEMS		
	Local Area Networks	55
	RayDat NET 6 PoE	56
	Bus Systems	59
	RayDat SBH-3 Series	60
	RayDat SGH-3 Series	62
	RayDat RS 485	64
	RayDat KNX	66
TELECOMMUNICATION SYSTEMS		
	Telecommunication Systems	69
	RayTel 10	70
	RayTel 20	72
	RayDat SPH-2-230	74
	RayDat SLH-2-110	76
	RayDat SLH-4-110	78
	RayDat SUI-4-110	80
	RayDat SRH-2-110	82
	RayDat SGH-3-110	84
COAXIAL & RF SYSTEMS		
	TV / Satellite / Video	87
	RayCox	88-90
	RayDat CP Series	92-108
POWER & SIGNAL LINES		
	DC Power Supply & Data	111
	RayDat SUH-2 PS	112
DC POWER SYSTEMS		
	DC Power Systems	115
	Raydat SPLH	116
	RayDat PSC-2	118
	ProTec DMDR 20 Series	120
	Regulatory Standards & References	122
	Product Index	126

RayDat Modular Features



RayDat surge protection for data and signal line systems provide unsurpassed electrical protection for signal power applications. These products meet the diverse requirements of industrial and other signal protection applications. RayDat products are available in a variety of operating voltages and configurations that conform to the latest industry standards and certifications.

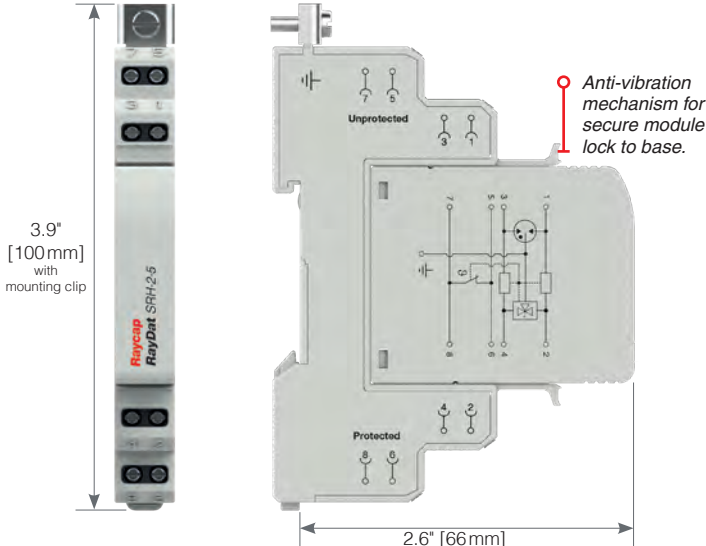

Raycap's anti-vibration mechanism ensures the pluggable surge protection modules remain locked onto their bases despite severe shock or vibration conditions.



RayDat SBH-3-5



RayDat SSH-3-24



RayDat SLH-4-30





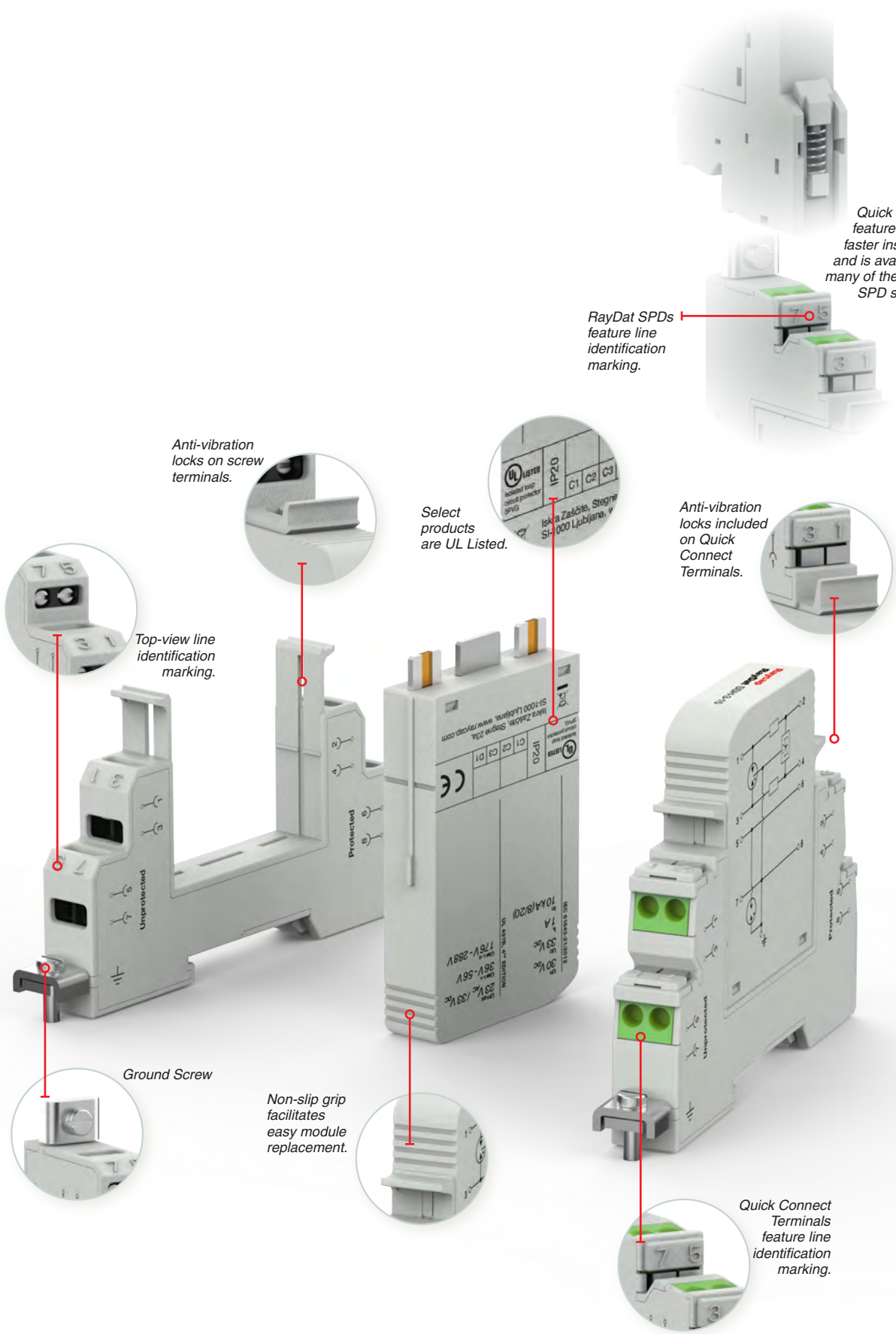



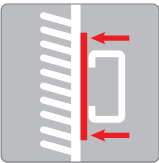
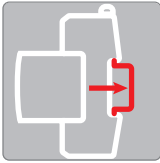
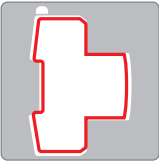

RayDat SPH-4-30

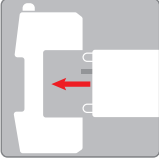

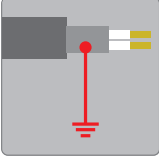
Icons Description

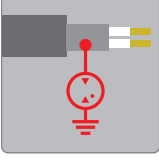

















 For easier selection see icons below and their descriptions.

			<p>Wall Mounted Product is designed to be mounted directly on a wall</p> 
<p>DIN Rail Mounted Products are mounted directly on a DIN Rail</p> 		<p>Compact Product Design Product housing is one piece, a non-pluggable design</p> 	
<p>Screw Connection Terminals Screw type connection for all protection lines</p> 		<p>Modular Product Design Product is designed in two pieces having a base and a replaceable plug in SPD module</p> 	
<p>Spring Connection Terminals Push-in connection for all protection lines</p> 		<p>Shield Directly Grounded Shield is connected to the Earth potential</p> 	
<p>Wire Connection Product is installed using integrated wires</p> 		<p>Shield Indirectly Grounded Shield is isolated with a GDT to the Earth potential</p> 	
<p>Plug-In Connection Product is ready to use, no special installation required</p> 		<p>EX Certificat SPD is certified for explosive environments</p> 	

Selection Guide

Signal & Data Transmission

















Signal Type	Mounting, Connection Type, Shield Handling, Pluggability	Recommended SPD	Category
0-20 mA, 4-20 mA Current Loops <i>* UL Listed</i>		RayDat SPH-2-30	D1/C1/C2/C3
		RayDat SPH-4-30	D1/C1/C2/C3
ARCNET		RayCox BNC 5	C1/C2/C3
Binary Signals <i>* UL Listed</i> <i>** UL Listed & CSA certified</i>		RayDat SPH-2-30	D1/C1/C2/C3
		RayDat SPH-4-30	D1/C1/C2/C3
		RayDat SLH-2 Series	D1/C1/C2/C3
		RayDat SLH-4 Series	D1/C1/C2/C3
		RayDat SGH-3 Series	D1/C1/C2/C3
		RayDat SSH-3 Series	D1/C1/C2/C3
		RayDat SUI-4 Series	D1/C1/C2/C3
	BITBUS (IEEE-1118) <i>* UL Listed</i>		RayDat SBH-3-5
CAN Bus (Data Line) <i>* UL Listed</i> <i>** UL Listed & CSA certified</i>		RayDat SBH-3-12	D1/C1/C2/C3
			RayDat SLH-2-12
	RayDat SLH-4-12		D1/C1/C2/C3
		RayDat SSH-3-12	D1/C1/C2/C3
	CAN Bus (Power Line)		RayDat PSC-2-24
ProTec DMDR 20/24			Class III Type 3
CAN Bus (Data line + Power Line)		RayDat SUH-2-24PS	D1/C1/C2/C3
CCTV ControlNet		RayCox BNC 12	C1/C2/C3

I_n [kA]	I_{imp} [kA]	Wires protected	Voltages [V]	I_L [A]	Page	Product Image
10kA	2.5kA	2	30*	1 A	34	
10kA	5kA	4	30*	1 A	36	
10kA	-	1	10	0.1 A	88	
10kA	2.5kA	2	30*	1 A	34	
10kA	5kA	4	30*	1 A	36	
10kA	2.5kA	2	5, 12, 15, 24, 30*, 48, 60	1 A	22	
10kA	5kA	4	5, 12**, 15, 24**, 30**, 48, 60	1 A	24	
10kA	2.5kA	3	5, 12, 15, 24, 30, 48, 60	1 A	62	
10kA	2.5kA	3	5*, 12*, 15, 24, 30*, 48, 60	1 A	26	
20kA	5kA	4	5, 12, 15, 24, 30*, 48, 60	1 A	30	
10kA	2.5kA	3	5*	1 A	60	
10kA	2.5kA	3	12*	1 A	60	
10kA	2.5kA	2	12	1 A	22	
10kA	5kA	4	12**	1 A	24	
10kA	2.5kA	3	12*	1 A	26	
10kA	-	2	24	4 A	118	
1.2kA	-	2	24	-	120	
10kA	2.5kA	2	24	1 A	112	
10kA	-	1	24	0.1 A	88	

-continued-

Signal & Data Transmission



















Signal Type	Mounting, Connection Type, Shield Handling, Pluggability	Recommended SPD	Category
Data Highway Plus * <i>UL Listed</i>		RayDat SBH-3-12	D1/C1/C2/C3
		RayDat SLH-2-12	D1/C1/C2/C3
		RayDat SLH-4-12	D1/C1/C2/C3
DeviceNet (Data Line) * <i>UL Listed</i> ** <i>UL Listed & CSA certified</i>		RayDat SBH-3-12	D1/C1/C2/C3
		RayDat SLH-2-12	D1/C1/C2/C3
		RayDat SLH-4-12	D1/C1/C2/C3
DeviceNet (Power Line)		RayDat PSC-2-24	C1/C2/C3
		ProTec DMDR 20/24	Class III Type 3
DeviceNet (Data + Power Line)		RayDat SUH-2-24PS	D1/C1/C2/C3
EIB KNX Bus		RayDat KNX	D1/C1/C2/C3
Ex(i) Circuits Fieldbus (Ex) PROFIBUS PA (Ex)		RayDat Ex-2	D1/C1/C2/C3
		RayDat PLP Ex	D1/C1/C2/C3
Ethernet CAT 6 Ethernet CAT 5 Power Over Ethernet (PoE) Industrial Ethernet Voice Over IP (VoIP) CDDI Token Ring * <i>UL Listed</i>		RayDat NET 6 POE	D1/C1/C2/C3
Genius Bus * <i>UL Listed</i> ** <i>UL Listed & CSA certified</i>		RayDat SLH-2-12	D1/C1/C2/C3
		RayDat SLH-4-12	D1/C1/C2/C3
		RayDat SSH-3-12	D1/C1/C2/C3

I_n [kA]	I_{imp} [kA]	Wires protected	Voltages [V]	I_L [A]	Page	Product Image
10kA	2.5kA	3	12*	1A	60	
10kA	2.5kA	2	12	1A	22	
10kA	5kA	4	12	1A	24	
10kA	2.5kA	3	12*	1A	60	
10kA	2.5kA	2	12	1A	22	
10kA	5kA	4	12**	1A	24	
10kA	2.5kA	3	12	1A	62	
10kA	-	2	24	4A	118	
1.2kA	-	2	24	-	120	
10kA	2.5kA	2	24	1A	112	
5kA	1kA	2	180	7A	66	
5kA	1kA	2	12, 24	0.5A	50	
up to 10kA	up to 2.0kA	2, 3, 4	24, 48	-	52	
150A	1kA	8	48*	1A	56	
10kA	2.5kA	2	12	1A	22	
10kA	5kA	4	12**	1A	24	
10kA	2.5kA	3	12*	1A	26	

-continued-

Signal & Data Transmission















Signal Type	Mounting, Connection Type, Shield Handling, Pluggability	Recommended SPD	Category
INTERBUS Inline (Remote) Modbus <i>* UL Listed</i>	    	RayDat SBH-3-5	D1/C1/C2/C3
	    	RayDat SLH-2-5	D1/C1/C2/C3
	    	RayDat SSH-3-5	D1/C1/C2/C3
INTERBUS Inline (I/O) <i>** UL Listed & CSA certified</i>	    	RayDat SLH-2-24	D1/C1/C2/C3
	    	RayDat SLH-4-24	D1/C1/C2/C3
	    	RayDat SUI-4-24	D1/C1/C2/C3
INTERBUS Field Multiplexer <i>* UL Listed</i>	    	RayDat SBH-3-5	D1/C1/C2/C3
	    	RayDat SGH-3-5	D1/C1/C2/C3
Local Operating Network (LON) <i>* UL Listed</i>	    	RayDat SBH-3-5	D1/C1/C2/C3
	    	RayDat SLH-2-5	D1/C1/C2/C3
	    	RayDat SLH-4-5	D1/C1/C2/C3
Opto Interface <i>* UL Listed</i>	    	RayDat SPH-2-30	D1/C1/C2/C3
	    	RayDat SPH-4-30	D1/C1/C2/C3
	    	RayDat SBH-3-30	D1/C1/C2/C3
	    	RayDat SSH-3-30	D1/C1/C2/C3
PROFIBUS DP⁽¹⁾/PA⁽²⁾ <i>* UL Listed</i> <i>** UL Listed & CSA certified</i>	    	RayDat SBH-3-5 ⁽¹⁾ RayDat SBH-3-30 ⁽²⁾	D1/C1/C2/C3
	    	RayDat SLH-2-5 ⁽¹⁾ RayDat SLH-2-24 ⁽²⁾	D1/C1/C2/C3

I_n [kA]	I_{imp} [kA]	Wires protected	Voltages [V]	I_L [A]	Page	Product Image
10kA	2.5kA	3	5*	1A	60	
10kA	2.5kA	2	5	1A	22	
10kA	2.5kA	3	5*	1A	26	
10kA	2.5kA	2	24	1A	22	
10kA	5kA	4	24**	1A	24	
20kA	5kA	4	24	1A	80	
10kA	2.5kA	3	5*	1A	60	
10kA	2.5kA	3	5	1A	62	
10kA	2.5kA	3	5*	1A	60	
10kA	2.5kA	2	5	1A	22	
10kA	5kA	4	5	1A	24	
10kA	2.5kA	3	5	1A	62	
10kA	2.5kA	2	30*	1A	34	
10kA	5kA	4	30*	1A	36	
10kA	2.5kA	3	30*	1A	60	
10kA	2.5kA	3	30*	1A	26	
10kA	2.5kA	3	5*, 30*	1A	60	
10kA	2.5kA	2	5, 24**	1A	22	

-continued-

Signal & Data Transmission



















Signal Type	Mounting, Connection Type, Shield Handling, Pluggability	Recommended SPD	Category
PROFIBUS DP⁽¹⁾/PA⁽²⁾ * <i>UL Listed</i>	    	RayDat SBH-3-5 ⁽¹⁾ RayDat SBH-3-30 ⁽²⁾	D1/C1/C2/C3
	    	RayDat SLH-2-5 ⁽¹⁾ RayDat SLH-2-24 ⁽²⁾	D1/C1/C2/C3
	    	RayDat SBH-3-30 ⁽²⁾	D1/C1/C2/C3
	    	RayDat SSH-3-5 ⁽¹⁾ RayDat SSH-3-30 ⁽²⁾	D1/C1/C2/C3
RS 232 * <i>UL Listed</i>	    	RayDat SBH-3-12	D1/C1/C2/C3
	    	RayDat SGH-3-12	D1/C1/C2/C3
RS 422, V.11, X.21 * <i>UL Listed</i> ** <i>UL Listed & CSA certified</i>	    	RayDat SLH-2-12	D1/C1/C2/C3
	    	RayDat SLH-4-12	D1/C1/C2/C3
	    	RayDat RS 485	D1/C1/C2/C3
RS 423A * <i>UL Listed</i> ** <i>UL Listed & CSA certified</i>	    	RayDat SLH-4-12	D1/C1/C2/C3
	    	RayDat RS 485	D1/C1/C2/C3
RS 485 * <i>UL Listed</i> ** <i>UL Listed & CSA certified</i>	    	RayDat SBH-3-12	D1/C1/C2/C3
	    	RayDat SSH-3-12	D1/C1/C2/C3
	    	RayDat SLH-4-12	D1/C1/C2/C3
	    	RayDat RS 485	D1/C1/C2/C3

I_n [kA]	I_{imp} [kA]	Wires protected	Voltages [V]	I_L [A]	Page	Product Image
10kA	2.5kA	3	5*, 30*	1A	60	
10kA	2.5kA	2	5, 24	1A	22	
10kA	2.5kA	3	30*	1A	60	
10kA	2.5kA	3	5*, 30*	1A	26	
10kA	2.5kA	3	12*	1A	60	
10kA	2.5kA	3	12	1A	62	
10kA	2.5kA	2	12	1A	22	
10kA	5kA	4	12**	1A	24	
20kA	2.5kA	6	5	0.5A	64	
10kA	2.5kA	4	12**	1A	24	
20kA	2.5kA	6	5	0.5A	64	
10kA	2.5kA	3	12*	1A	60	
10kA	2.5kA	3	12*	1A	26	
10kA	2.5kA	4	12**	1A	24	
20kA	2.5kA	6	5	0.5A	64	

-continued-

Signal & Data Transmission















Signal Type	Mounting, Connection Type, Shield Handling, Pluggability	Recommended SPD	Category	
Synchronous Data Link Control (SDLC) * <i>UL Listed</i>		RayDat SLH-2-5	D1/C1/C2/C3	
		RayDat SLH-4-5	D1/C1/C2/C3	
		RayDat SGH-3-5	D1/C1/C2/C3	
			RayDat SSH-3-5	D1/C1/C2/C3
	SINEC L1, SINEC L2 * <i>UL Listed</i>			RayDat SLH-2-5
		RayDat SLH-4-5		D1/C1/C2/C3
		RayDat SBH-3-5	D1/C1/C2/C3	
			RayDat SSH-3-5	D1/C1/C2/C3
Suconet				RayDat SLH-4-5
				RayDat RS 485
Temperature Measurement * <i>UL Listed</i>		RayDat SPH-2-30	D1/C1/C2/C3	
		RayDat SPH-4-30	D1/C1/C2/C3	
		RayDat SBH-3-30	D1/C1/C2/C3	
			RayDat SSH-3-30	D1/C1/C2/C3
TTL * <i>UL Listed</i> ** <i>UL Listed & CSA certified</i>			RayDat SLH-2-12	D1/C1/C2/C3
		RayDat SLH-4-12	D1/C1/C2/C3	
		RayDat SBH-3-12	D1/C1/C2/C3	
			RayDat SSH-3-12	D1/C1/C2/C3

I_n [kA]	I_{imp} [kA]	Wires protected	Voltages [V]	I_L [A]	Page	Product Image
10kA	2.5kA	2	5	1 A	22	
10kA	5kA	4	5	1 A	24	
10kA	2.5kA	3	5	1 A	62	
10kA	2.5kA	3	5*	1 A	26	
10kA	2.5kA	2	5	1 A	22	
10kA	5kA	4	5	1 A	24	
10kA	2.5kA	3	5*	1 A	60	
10kA	2.5kA	3	5*	1 A	26	
10kA	2.5kA	4	5	1 A	24	
20kA	2.5kA	6	5	0.5 A	64	
10kA	2.5kA	2	30*	1 A	34	
10kA	5kA	4	30*	1 A	36	
10kA	2.5kA	3	30*	1 A	60	
10kA	2.5kA	3	30*	1 A	26	
10kA	2.5kA	2	12	1 A	22	
10kA	5kA	4	12**	1 A	24	
10kA	2.5kA	3	12*	1 A	60	
10kA	2.5kA	3	12*	1 A	26	

-continued-

Telecommunication



















Signal Type	Mounting, Connection Type, Shield Handling, Pluggability	Recommended SPD	Category
ADSL, ADSL2, ADSL 2+		RayTel 20	D1/C1/C2/C3
		RayTel 10	C1/C2/C3
		RayDat SLH-2-110	D1/C1/C2/C3
		RayDat SPH-2-230	D1/C1/C2/C3
E1 * UL Listed ** UL Listed & CSA certified		RayDat NET 6 POE	D1/C1/C2/C3
		RayDat SLH-4-24	D1/C1/C2/C3
		RayDat SPH-4-30	D1/C1/C2/C3
		RayDat SUI-4-24	D1/C1/C2/C3
		RayDat NET 6 POE	D1/C1/C2/C3
			RayDat SLH-4-24
G.703/G.704 * UL Listed		RayDat SPH-4-30	D1/C1/C2/C3
		RayDat SUI-4-24	D1/C1/C2/C3
HDSL * UL Listed ** UL Listed & CSA certified		RayDat SLH-4-24	D1/C1/C2/C3
		RayDat SPH-4-30	D1/C1/C2/C3
		RayDat SUI-4-24	D1/C1/C2/C3
		RayDat NET 6 POE	D1/C1/C2/C3
ISDN S ₀ * UL Listed ** UL Listed & CSA certified		RayDat SLH-4-12	D1/C1/C2/C3
		RayDat NET 6 POE	D1/C1/C2/C3

I_n [kA]	I_{imp} [kA]	Wires protected	Voltages [V]	I_L [A]	Page	Product Image
10kA	2.5kA	2	110	0.6A	72	
2.5kA	-	2	110	0.15A	70	
10kA	2.5kA	2	110	1A	76	
10kA	2.5kA	2	230	5A	74	
150A	1kA	8	48*	1A	56	
10kA	5kA	4	24**	1A	24	
10kA	5kA	4	30*	1A	36	
20kA	5kA	4	24	1A	30	
150A	1kA	8	48*	1A	56	
10kA	5kA	4	24	1A	24	
10kA	5kA	4	30*	1A	36	
20kA	5kA	4	24	1A	30	
10kA	5kA	4	24**	1A	24	
10kA	5kA	4	30*	1A	36	
20kA	5kA	4	24	1A	30	
150A	1kA	8	48*	1A	56	
10kA	5kA	4	12**	1A	24	
150A	1kA	8	48*	1A	56	

-continued-

Telecommunication

Signal Type	Mounting, Connection Type, Shield Handling, Pluggability	Recommended SPD	Category
ISDN U _o		RayDat SLH-2-110	D1/C1/C2/C3
		RayDat SPH-2-230	D1/C1/C2/C3
		RayTel 20	D1/C1/C2/C3
		RayTel 10	C1/C2/C3
POTS		RayDat SLH-2-110	D1/C1/C2/C3
		RayDat SPH-2-230	D1/C1/C2/C3
		RayTel 20	D1/C1/C2/C3
		RayTel 10	C1/C2/C3
SDSL <i>* UL Listed</i>		RayDat SLH-4-12	D1/C1/C2/C3
		RayDat NET 6 POE	D1/C1/C2/C3
SHDSL		RayDat SGH-3-5	D1/C1/C2/C3
		RayDat SLH-2-5	D1/C1/C2/C3
		RayDat SLH-4-5	D1/C1/C2/C3
T-DSL		RayDat SLH-2-110	D1/C1/C2/C3
		RayDat SPH-2-230	D1/C1/C2/C3
		RayTel 20	D1/C1/C2/C3
		RayTel 10	C1/C2/C3
VDSL		RayTel 20	D1/C1/C2/C3
		RayTel 10	C1/C2/C3
		RayDat SLH-2-110	D1/C1/C2/C3
		RayDat SPH-2-230	D1/C1/C2/C3

I_n [kA]	I_{imp} [kA]	Wires protected	Voltages [V]	I_L [A]	Page	Product Image
10kA	2.5kA	2	110	1 A	76	
10kA	2.5kA	2	230	5 A	74	
10kA	2.5kA	2	110	0.6 A	72	
2.5kA	-	2	110	0.15 A	70	
10kA	2.5kA	2	110	1 A	76	
10kA	2.5kA	2	230	5 A	74	
10kA	2.5kA	2	110	0.6 A	72	
2.5kA	-	2	110	0.15 A	70	
10kA	5kA	4	12	1 A	24	
150 A	1kA	8	48*	1 A	56	
10kA	2.5kA	3	5	1 A	62	
10kA	2.5kA	2	5	1 A	22	
10kA	5kA	4	5	1 A	24	
10kA	2.5kA	2	110	1 A	76	
10kA	2.5kA	2	230	5 A	74	
10kA	2.5kA	2	110	0.6 A	72	
2.5kA	-	2	110	0.15 A	70	
10kA	2.5kA	2	110	0.6 A	72	
2.5kA	-	2	110	0.15 A	70	
10kA	2.5kA	2	110	1 A	76	
10kA	2.5kA	2	230	5 A	74	

Modular Surge Protective Devices (SPDs) for Data & Signal Lines



RayDat SL Series

Special features:

- Very high surge ratings
- The connection lines remain enabled during module replacement
- High density – up to 4 protected lines at only 12mm width
- Equipped with Screw or Quick connect (spring loaded) terminals

- RayDat SLH-2*
- RayDat SLH-4**
- RayDat SSH-3*
- RayDat SLL-4*
- RayDat SUI-4*

*UL Listed
 ** UL Listed & CSA certified



Symbol Legend:

- DIN Rail Mounting
- Screw Connect Terminals
- Quick Connect Terminals
- Modular design
- Shield Directly Grounded
- Shield Indirectly Grounded

These efficient overvoltage barriers (except RayDat SLL) contain both, coarse and fine protection stages, and provide longitudinal and a transverse surge protection, while RayDat SLL contains fine protection stage only.

The initial protection stage comprises a three-pole gas discharge tube (GDT) that is designed to divert the primary surge energy. The subsequent fine protection stage is carried out using fast bi-directional silicon avalanche diodes (SAD). Care is taken in the design of the fine protection stage to avoid capacitive line loading, thereby ensuring a low insertion loss and wide operating frequency range.

Series line impedances ensure energy coordination between the coarse and a fine protection stages at all levels of a surge incident. To protect against the hazards of electric shock and fire, which often results when power frequency (or lines frequency) contact occurs between power and communication lines (often called mains incursion), a thermo-clip is included on the primary protection stage to divert the power frequency current to ground.

The plug-in module/base design facilitates replacement of a failed module without the need to remove system wiring. If the module is unplugged from the base, the connection lines remain enabled.



Modular SPD for Single Pair RayDat SLH-2 Series

D1 • C1 • C2 • C3

*UL Listed



IEC/EN Category: D1/C1/C2/C3
 Surge Discharge Ratings: I_n : 10 kA, I_{max} : 20 kA, I_{imp} : 2.5 kA
 Voltages: 5, 12, 15, 24, 30*, 48, 60 V DC
 Frequency Range: 30 MHz
 Housing: Modular Design
 Compliance: IEC/EN 61643-21
 UL 497B 4th Edition

Configuration:

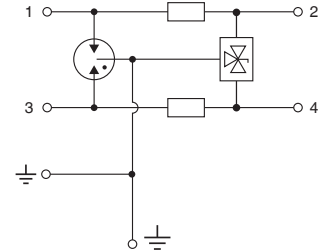

Technical Data

SLH-2 Series		5	12	15	24	30*	48	60
Electrical								
Lines Protected		1 (2 Conductors)						
Nominal Operating Voltage (DC)	U_n	5V	12V	15V	24V	30V	48V	60V
Maximum Continuous Operating Voltage (DC)	U_c	6V	15V	18V	28V	33V	52V	64V
Rated Load Current at 25°C	I_L	1 A						
C2 Nominal Discharge Current (8/20µs)	I_n	10 kA						
Maximum Discharge Current (8/20µs)	I_{max}	20 kA						
D1 Impulse Current (10/350µs)	I_{imp}	2.5 kA						
Residual Voltage at 5kA (8/20µs)	U_{res}	<22V	<42V	<48V	<70V	<80V	<140V	<160V
Rated Spark Overvoltage	(Line-Ground)	7-10V	16-21V	21-25V	31-37V	36-44V	57-69V	68-84V
	(Line-Line)	7-10V	16-21V	21-25V	31-37V	36-44V	57-69V	68-84V
Response Time Overvoltage Protection	t_A	<1 ns						
Thermal Protection		Yes						
Insulation Resistance of the Protection	R_{iso}	≥ 6 KΩ	≥ 15 MΩ	≥ 18 MΩ	≥ 28 MΩ	≥ 33 MΩ	≥ 52 MΩ	≥ 64 MΩ
Serial Resistance per Path	R	1.6-2.0 Ω						
Transverse Capacitance	C	50 pF						
Cut-off Frequency	f_G	30 MHz						
Mechanical								
Temperature Range		-40 °F to +176 °F [-40 °C to +80 °C]						
Terminal Cross Section Multi-strand (max.)		12 AWG [4 mm ² , 2.5 mm ² Q Version]						
Terminal Screw Torque		4.5 lbf-in [0.5 Nm]						
Degree of Protection IEC/EN 60529		IP20 (built-in)						
Housing Material		Thermoplastic; Grey; Extinguishing Degree V-0						
Mounting IEC/EN 60715		35mm DIN Rail						
Order Information								
Order Code		5	12	15	24	30*	48	60
SLH-2-xxx		7086.33	7086.34	7086.35	7086.36	7082.80	7086.37	7086.38
SLH-2-xxxQ (Quick Connect Terminals)		7085.05	7085.06	7085.07	7085.08	7085.09	7085.10	7085.11
SLH-2-xxxM (module)		7086.40	7086.41	7086.42	7086.43	7082.81	7086.44	7086.45

RayDat SLH-2 Series

Internal Configuration

Legend

- DB Diode Block
- GDT Gas Discharge Tube
- PG Protective Grounding
- R Resistor
- TC Thermo-clip

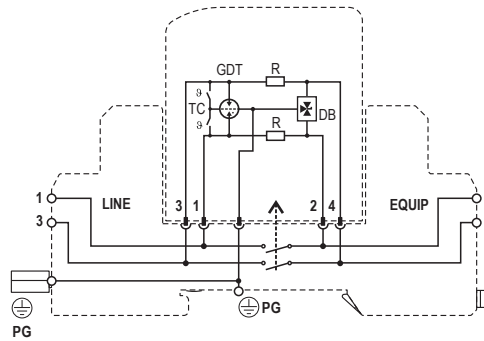

Dimensions & Packaging

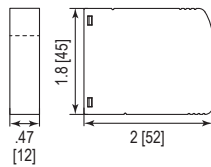
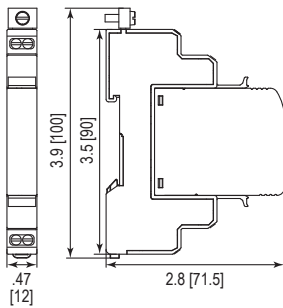

SLH-2 Series	5	12	15	24	30	48	60
Dimensions							
Weight per Unit	1.83 oz [52 g]						
Dimensions DIN 43880	2/3 TE						
Packaging Dimensions (Single Unit)	3.4 x .59 x 4" [87 x 15 x 102 mm]						
Minimum Package Quantity	15 pieces						

SLH-2-xxxM Series	5	12	15	24	30	48	60
Dimensions							
Weight per Unit	.84 oz [24 g]						
Packaging Dimensions (Single Unit)	3.4 x .59 x 4" [87 x 15 x 102 mm]						
Minimum Package Quantity	15 pieces						

Quick Connect Terminals

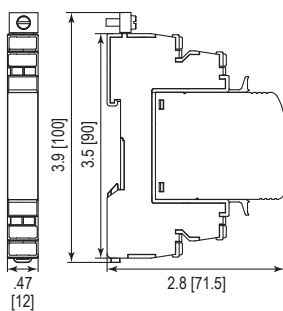

SLH-2-xxxQ Series	5	12	15	24	30	48	60
Dimensions							
Weight per Unit	1.90 oz [54 g]						
Dimensions DIN 43880	2/3 TE						
Packaging Dimensions (Single Unit)	3.4 x .59 x 4" [87 x 15 x 102 mm]						
Minimum Package Quantity	15 pieces						

inches
[mm]



Modular SPD for Two Pair RayDat SLH-4 Series D1 • C1 • C2 • C3

*UL Listed, CSA Certified



IEC/EN Category: D1/C1/C2/C3
Surge Discharge Ratings: I_n : 10 kA, I_{max} : 20 kA, I_{imp} : 5 kA
Voltages: 5, 12*, 15, 24*, 30*, 48, 60 V DC
Frequency Range: 30 MHz
Housing: Modular Design
Compliance: IEC/EN 61643-21
UL 497B 4th Edition
CSA C22.2 No. 226.92

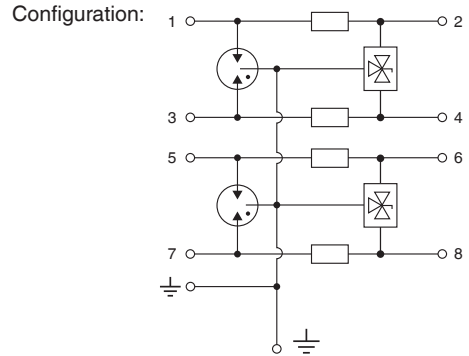

Technical Data

SLH-4 Series		5	12*	15	24*	30*	48	60
Electrical								
Lines Protected		2 (4 Conductors)						
Nominal Operating Voltage (DC)	U_n	5V	12V	15V	24V	30V	48V	60V
Maximum Continuous Operating Voltage (DC)	U_c	6V	15V	18V	28V	33V	52V	64V
Rated Load Current at 25°C	I_L	1 A						
C2 Nominal Discharge Current (8/20µs)	I_n	10 kA						
Maximum Discharge Current (8/20µs)	I_{max}	20 kA						
D1 Impulse Current (10/350µs)	I_{imp}	5 kA						
Residual Voltage at 5kA (8/20µs)	U_{res}	<22V	<42V	<48V	<70V	<80V	<140V	<160V
Rated Spark Overvoltage	(Line-Ground)	7-10V	17-21V	21-25V	31-37V	36-44V	57-69V	68-84V
	(Line-Line)	7-10V	17-21V	21-25V	31-37V	36-44V	57-69V	68-84V
Response Time Overvoltage Protection	t_A	<1 ns						
Thermal Protection		Yes						
Insulation Resistance of the Protection	R_{iso}	≥ 6 KΩ	≥ 15 MΩ	≥ 18 MΩ	≥ 28 MΩ	≥ 33 MΩ	≥ 52 MΩ	≥ 64 MΩ
Serial Resistance per Path	R	1.6-2.0Ω						
Transverse Capacitance	C	50 pF						
Cut-off Frequency	f_G	30 MHz						
Mechanical								
Temperature Range		-40 °F to +176 °F [-40 °C to +80 °C]						
Terminal Cross Section Multi-strand (max.)		12 AWG [4 mm ² , 2.5 mm ² Q Version]						
Terminal Screw Torque		4.5 lbf-in [0.5 Nm]						
Degree of Protection IEC/EN 60529		IP20 (built-in)						
Housing Material		Thermoplastic; Grey; Extinguishing Degree V-0						
Mounting IEC/EN 60715		35mm DIN Rail						
Order Information								
Order Code		5	12*	15	24*	30*	48	60
SLH-4-xxx		7086.47	7086.48	7086.49	7086.50	7082.78	7086.51	7086.52
SLH-4-xxxQ (Quick Connect Terminals)		7085.13	7085.14	7085.15	7085.16	7085.17	7085.18	7085.19
SLH-4-xxxM (module)		7086.54	7086.55	7086.56	7086.57	7082.79	7086.58	7086.59

RayDat SLH-4 Series

Internal Configuration

Legend

- DB Diode Block
- GDT Gas Discharge Tube
- PG Protective Grounding
- R Resistor
- TC Thermo-clip

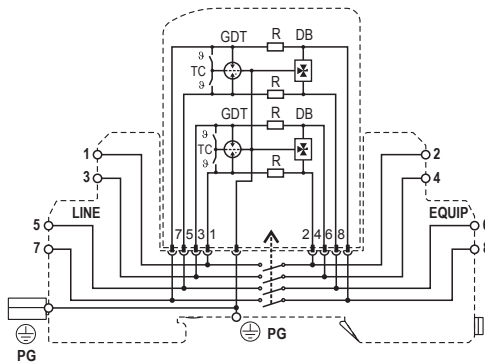

Dimensions & Packaging

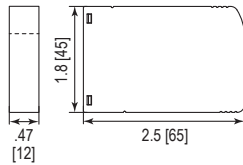
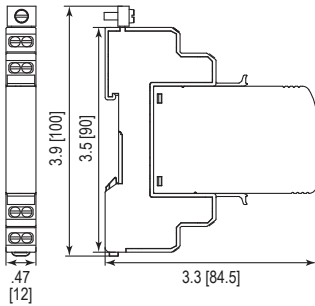

SLH-4 Series	5	12	15	24	30	48	60
Dimensions							
Weight per Unit	2.32 oz [66 g]						
Dimensions DIN 43880	2/3 TE						
Packaging Dimensions (Single Unit)	3.4 x .59 x 4" [87 x 15 x 102 mm]						
Minimum Package Quantity	15 pieces						

SLH-4-xxxM Series	5	12	15	24	30	48	60
Dimensions							
Weight per Unit	1.05 oz [30 g]						
Packaging Dimensions (Single Unit)	3.4 x .59 x 4" [87 x 15 x 102 mm]						
Minimum Package Quantity	15 pieces						

Quick Connect Terminals

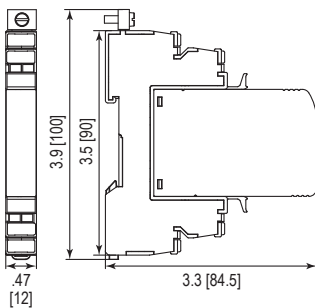

SLH-4-xxxQ Series	5	12	15	24	30	48	60
Dimensions							
Weight per Unit	2.32 oz [66 g]						
Dimensions DIN 43880	2/3 TE						
Packaging Dimensions (Single Unit)	3.4 x .59 x 4" [87 x 15 x 102 mm]						
Minimum Package Quantity	15 pieces						

inches
[mm]



SPD for Shielded Cable

RayDat SSH-3 Series

D1 • C1 • C2 • C3

*UL Listed



IEC/EN Category: D1/C1/C2/C3
 Surge Discharge Ratings: I_n : 10 kA, I_{max} : 20 kA, I_{imp} : 2.5 kA
 Voltages: 5*, 12*, 15, 24, 30*, 48, 60 V DC
 Frequency Range: 30 MHz
 Housing: Modular Design
 Compliance: IEC/EN 61643-21
 UL 497B 4th Edition

Configuration:

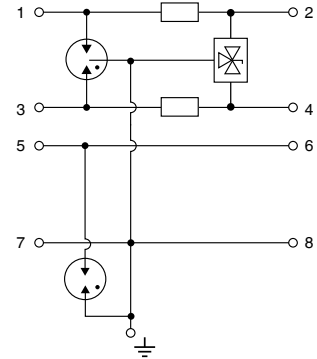

Technical Data

SSH-3 Series		5*	12*	15	24	30*	48	60
Electrical								
Lines Protected		1 (2 Conductors)						
Nominal Operating Voltage (DC)	U_n	5V	12V	15V	24V	30V	48V	60V
Maximum Continuous Operating Voltage (DC)	U_c	6V	15V	18V	28V	33V	52V	64V
Rated Load Current at 25°C	I_L	1 A						
C2 Nominal Discharge Current (8/20 μs)	I_n	10 kA						
Maximum Discharge Current (8/20 μs)	I_{max}	20 kA						
D1 Impulse Current (10/350 μs)	I_{imp}	2.5 kA						
Residual Voltage at 5 kA (8/20 μs)	(Line-Line) U_{res}	<22V	<42V	<48V	<70V	<80V	<140V	<160V
Rated Spark Overvoltage	(Shield-Ground)	184-276V						
	(Line-Line), (Line-Ground)	7-10V	16-21V	20-24V	30-36V	35-43V	55-68V	67-85V
Response Time Overvoltage Protection (Shield-Ground)	t_A	<100ns						
	(Line-Line), (Line-Ground)	<1 ns						
Insulation Resistance of the Protection (Shield-Ground)	R_{iso}	> 1 GΩ/100V						
	(Line-Line), (Line-Ground)	≥ 6 KΩ	≥ 15 MΩ	≥ 18 MΩ	≥ 28 MΩ	≥ 33 MΩ	≥ 52 MΩ	≥ 64 MΩ
Serial Resistance per Path	R	1.6-2.0 Ω						
Transverse Capacitance	(Shield-Ground) C	5 pF						
	(Line-Line), (Line-Ground)	50 pF						
Cut-off Frequency	f_G	30 MHz						
Mechanical								
Temperature Range		-40 °F to +176 °F [-40 °C to +80 °C]						
Terminal Cross Section Multi-strand (max.)		12 AWG [4 mm ² , 2.5 mm ² Q Version]						
Terminal Screw Torque		4.5 lbf-in [0.5 Nm]						
Degree of Protection IEC/EN 60529		IP 20 (built-in)						
Housing Material		Thermoplastic; Grey; Extinguishing Degree V-0						
Mounting IEC/EN 60715		35mm DIN Rail						
Order Information								
Order Code		5*	12*	15	24	30*	48	60
SSH-3-xxx		7086.01	7086.02	7086.03	7086.04	7086.05	7086.06	7086.07
SSH-3-xxxQ (Quick Connect Terminals)		7086.90	7086.91	7086.92	7086.93	7086.94	7086.95	7086.96
SSH-3-xxxM (module)		7086.09	7086.10	7086.11	7086.12	7086.13	7086.14	7086.15

RayDat SSH-3 Series

Internal Configuration

Legend

- DB Diode Block
- GDT Gas Discharge Tube
- PG Protective Grounding
- R Resistor
- SH Shielded
- TC Thermo-clip

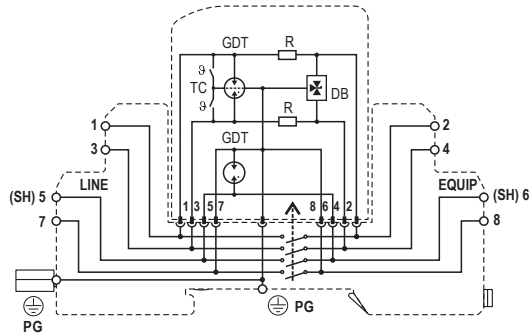

Dimensions & Packaging

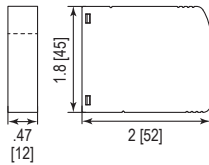
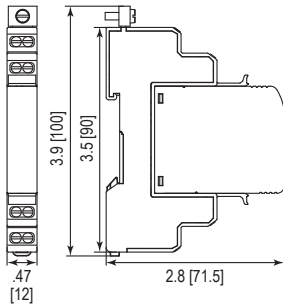

SSH-3 Series	5	12	15	24	30	48	60
Dimensions							
Weight per Unit	2.11 oz [60g]						
Dimensions DIN 43880	2/3 TE						
Packaging Dimensions (Single Unit)	3.4 x .59 x 4" [87 x 15 x 102mm]						
Minimum Package Quantity	15 pieces						

SSH-3-xxxM Series	5	12	15	24	30	48	60
Dimensions							
Weight per Unit	.91 oz [26g]						
Packaging Dimensions (Single Unit)	3.4 x .59 x 4" [87 x 15 x 102mm]						
Minimum Package Quantity	15 pieces						

Quick Connect Terminals

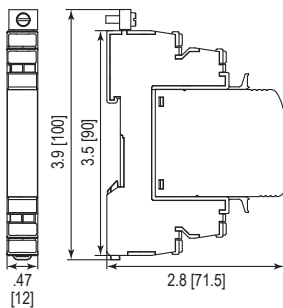

SSH-3-xxxQ Series	5	12	15	24	30	48	60
Dimensions							
Weight per Unit	2.18 oz [62g]						
Dimensions DIN 43880	2/3 TE						
Packaging Dimensions (Single Unit)	3.4 x .59 x 4" [87 x 15 x 102mm]						
Minimum Package Quantity	15 pieces						

inches
[mm]



SPD for Two Pair with Single Protection Mode

RayDat SLL-4 Series

C1 • C3

UL Listed



IEC/EN Category: C1/C3
 Surge Discharge Ratings: I_n : 250 A
 Voltages: 30 V DC
 Frequency Range: 30 MHz
 Housing: Modular Design
 Compliance: IEC/EN 61643-21
 UL 497B 4th Edition

Configuration:

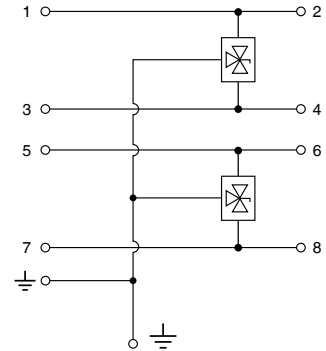

Technical Data

SLL-4 Series

30

Electrical

Lines Protected		2 (4 Conductors)
Nominal Operating Voltage (DC)	U_n	30V
Maximum Continuous Operating Voltage (DC)	U_c	33V
Rated Load Current at 25°C	I_L	10 A
C1 Nominal Discharge Current (8/20 μs)	I_n	250 A
Residual Voltage at 5 kA (8/20 μs)	(Line-Line) U_{res}	< 80V
Rated Spark Overvoltage	(Line-Line)	36-44V
	(Line-Ground)	36-44V
Response Time Overvoltage Protection	(Line-Line) t_A	< 1 ns
	(Line-Ground)	< 1 ns
Insulation Resistance of the Protection	(Line-Line) R_{iso}	≥ 33 MΩ
	(Line-Ground)	≥ 33 MΩ
Serial Resistance per Path	R	0.1 Ω
Transverse Capacitance	(Line-Line) C	50 pF
	(Line-Line)	50 pF
Cut-off Frequency	f_G	30 MHz

Mechanical

Temperature Range	-40 °F to +176 °F [-40 °C to +80 °C]
Terminal Cross Section Multi-strand (max.)	12 AWG [4 mm ² , 2.5 mm ² Q Version]
Terminal Screw Torque	4.5 lbf-in [0.5 Nm]
Degree of Protection IEC/EN 60529	IP20 (built-in)
Housing Material	Thermoplastic; Grey; Extinguishing Degree V-0
Mounting IEC/EN 60715	35 mm DIN Rail

Order Information

Order Code	30
SLL-4-xx	7082.92
SLL-4-xxQ (Quick Connect Terminals)	7085.27
SLL-4-xxM (module)	7082.93

RayDat SLL-4 Series

Internal Configuration

Legend

DB Diode Block
PG Protective Grounding

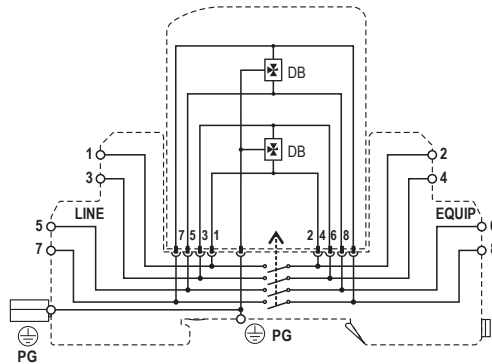

Dimensions & Packaging

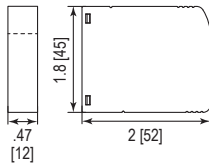
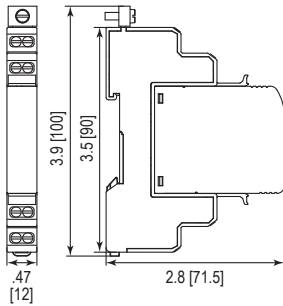

SLL-4 Series

30

Dimensions

Weight per Unit 1.97 oz [56g]

Dimensions DIN 43880 2/3 TE

Packaging Dimensions (Single Unit) 3.4 x .59 x 4" [87 x 15 x 102 mm]

Minimum Package Quantity 15 pieces

SLL-4-xxM Series

30

Dimensions

Weight per Unit .77 oz [22g]

Packaging Dimensions (Single Unit) 3.4 x .59 x 4" [87 x 15 x 102 mm]

Minimum Package Quantity 15 pieces

Quick Connect Terminals

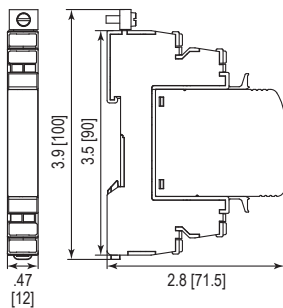

SLL-4-xxQ Series

30

Dimensions

Weight per Unit 2.04 oz [58g]

Dimensions DIN 43880 2/3 TE

Packaging Dimensions (Single Unit) 3.4 x .59 x 4" [87 x 15 x 102 mm]

Minimum Package Quantity 15 pieces

inches
[mm]

SPD for Two Pair Exposed Lines

RayDat SUI-4 Series

D1 • C1 • C2 • C3

*UL Listed



IEC/EN Category: D1/C1/C2/C3
 Surge Discharge Ratings: I_n : 20 kA, I_{max} : 30 kA, I_{imp} : 5 kA
 Voltages: 5, 12, 15, 24, 30*, 48, 60V DC
 Frequency Range: 30 MHz
 Housing: Modular Design
 Compliance: IEC/EN 61643-21
 UL 497B 4th Edition

Configuration:

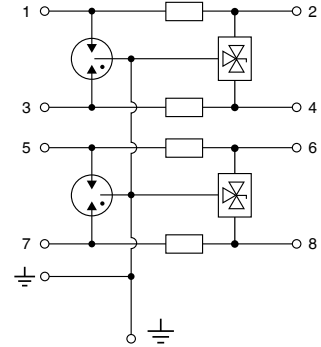

Technical Data

SUI-4 Series		5	12	15	24	30*	48	60
Electrical								
Lines Protected		2 (4 Conductors)						
Nominal Operating Voltage (DC)	U_n	5V	12V	15V	24V	30V	48V	60V
Maximum Continuous Operating Voltage (DC)	U_c	6V	15V	18V	28V	33V	52V	64V
Rated Load Current at 25°C	I_L	1 A						
C2 Nominal Discharge Current (8/20µs)	I_n	20 kA						
Maximum Discharge Current (8/20µs)	I_{max}	30 kA						
D1 Impulse Current (10/350µs)	I_{imp}	5 kA						
Residual Voltage at 5kA (8/20µs)	U_{res}	<22V	<42V	<48V	<70V	<80V	<140V	<160V
Rated Spark Overvoltage	(Line-Ground)	7-10V	16-21V	21-25V	31-37V	36-44V	57-69V	68-84V
	(Line-Line)	7-10V	16-21V	21-25V	31-37V	36-44V	57-69V	68-84V
Response Time Overvoltage Protection	t_A	<1 ns						
Thermal Protection		Yes						
Insulation Resistance of the Protection	R_{iso}	≥ 6 KΩ	≥ 15 MΩ	≥ 18 MΩ	≥ 28 MΩ	≥ 33 MΩ	≥ 52 MΩ	≥ 64 MΩ
Serial Resistance per Path	R	1.6-2.0Ω						
Transverse Capacitance	C	50 pF						
Cut-off Frequency	f_G	30 MHz						
Mechanical								
Temperature Range		-40 °F to +176 °F [-40 °C to +80 °C]						
Terminal Cross Section Multi-strand (max.)		12 AWG [4 mm ²]						
Terminal Screw Torque		4.5 lbf-in [0.5 Nm]						
Degree of Protection IEC/EN 60529		IP20 (built-in)						
Housing Material		Thermoplastic; Grey; Extinguishing Degree V-0						
Mounting IEC/EN 60715		35mm DIN Rail						
Order Information								
Order Code		5	12	15	24	30*	48	60
SUI-4-xxx		7083.21	7083.22	7083.23	7083.24	7083.25	7083.26	7083.27
SUI-4-xxxM (module)		7083.29	7083.30	7083.31	7083.32	7083.33	7083.34	7083.35

RayDat SUI-4 Series

Internal Configuration

Legend

- DB Diode Block
- GDT Gas Discharge Tube
- PG Protective Grounding
- R Resistor
- TC Thermo-clip

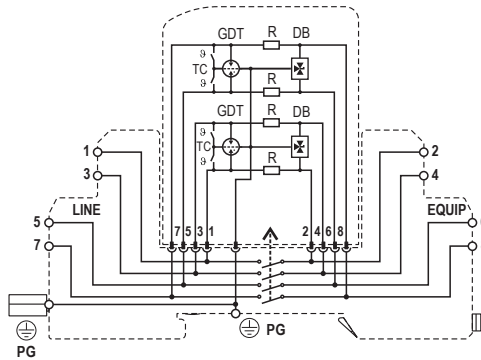

Dimensions & Packaging

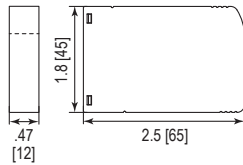
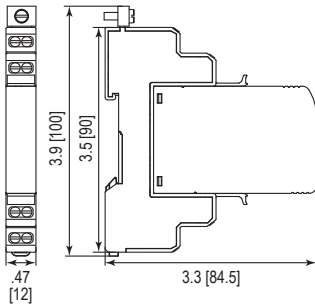

SUI-4 Series	5	12	15	24	30	48	60
Dimensions							
Weight per Unit	2.46 oz [70g]						
Dimensions DIN 43880	2/3 TE						
Packaging Dimensions (Single Unit)	3.4 x .59 x 4" [87 x 15 x 102mm]						
Minimum Package Quantity	15 pieces						

SUI-4-xxxM Series	5	12	15	24	30	48	60
Dimensions							
Weight per Unit	1.05 oz [30g]						
Packaging Dimensions (Single Unit)	3.4 x .59 x 4" [87 x 15 x 102mm]						
Minimum Package Quantity	15 pieces						

inches
[mm]





Modular Surge Protective Devices (SPDs) for Data & Signal Lines



RayDat SP Series

RayDat SPH-2*
 RayDat SPH-4*
 RayDat SPI-2
 RayDat SPI-4



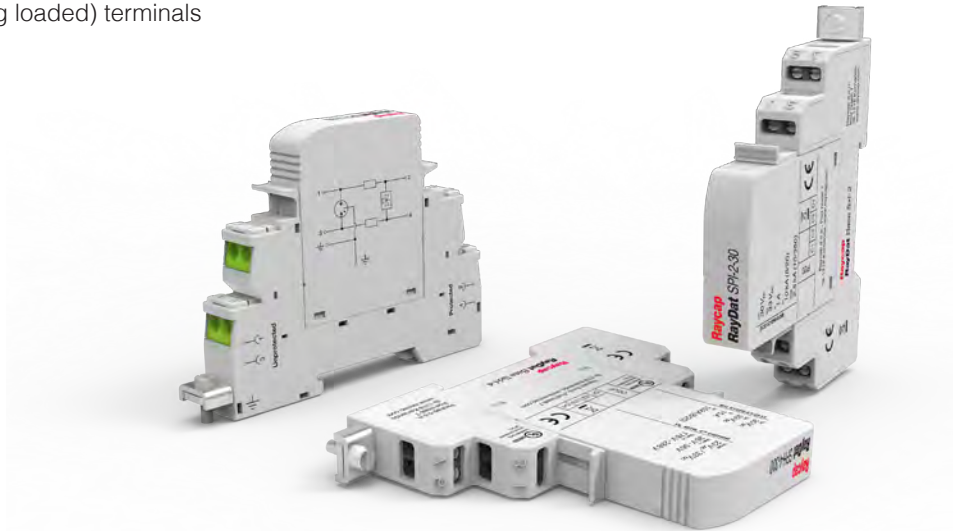

Special features:

*UL Listed

- Very high surge ratings
- The connection lines remain enabled during module replacement
- High density – up to 2 protected pairs at only 12mm width
- Equipped with Screw or Quick connect (spring loaded) terminals



Symbol Legend:

-  DIN Rail Mounting
-  Screw Connect Terminals
-  Quick Connect Terminals
-  Modular design
-  Shield Directly Grounded

The RayDat SP Series of surge protective devices has been developed to protect a pair loop, which could be ungrounded onto data, signal and communication circuits. It is intended for those applications where high ground potential rises may frequently occur, such as in locations close to electric railways. The circuit topology consists of a multi-stage protector providing both, common (longitudinal) mode and differential (transverse) mode protection. Coarse protection is provided by a three terminal gas discharge tube (GDT), while fine protection is provided using a high-speed silicon avalanche diode (SAD) or metal oxide varistor (MOV) stage.

Care is taken between these two stages to ensure coordination without voltage or surge current blind spots occurring. Thermal protection reduces the hazards of thermal runaway, should there be an inadvertent mains incursion fault. Both common (longitudinal) mode and differential (transverse) mode protection is provided. If the module is unplugged from the base, the connection lines remain enabled.



Modular SPD for Single Pair RayDat SPH-2 Series

D1 • C1 • C2 • C3

UL Listed



IEC/EN Category: D1/C1/C2/C3
 Surge Discharge Ratings: I_n : 10 kA, I_{max} : 20 kA, I_{imp} : 2.5 kA
 Voltages: 30 V DC
 Frequency Range: 30 MHz, 10 MHz
 Housing: Modular Design
 Compliance: IEC/EN 61643-21
 UL 497B 4th Edition

Configuration:

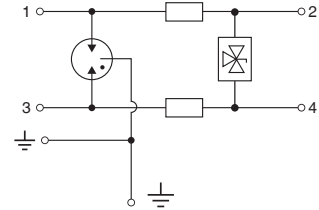

Technical Data

SPH-2 Series

30

Electrical

Lines Protected		1 (2 Conductors)
Nominal Operating Voltage (DC)	U_n	30V
Maximum Continuous Operating Voltage (DC)	U_c	33V
Rated Load Current at 25°C	I_L	1 A
C2 Nominal Discharge Current (8/20 μ s)	I_n	10 kA
Maximum Discharge Current (8/20 μ s)	I_{max}	20 kA
D1 Impulse Current (10/350 μ s)	I_{imp}	2.5 kA
Residual Voltage at 5 kA (8/20 μ s)	(Line-Line) U_{res}	< 80V
Rated Spark Overvoltage	(Line-Ground)	184-276V
	(Line-Line)	36-44V
Response Time Overvoltage Protection	(Line-Line) t_A	< 1 ns
	(Line-Ground)	< 100 ns
Insulation Resistance of the Protection	(Line-Ground) R_{iso}	> 1 G Ω /100V
	(Line-Line)	\geq 33 M Ω
Serial Resistance per Path	R	1.6-2.0 Ω
Transverse Capacitance	(Line-Line) C	50 pF
	(Line-Ground)	5 pF
Cut-off Frequency	f_G	30 MHz

Mechanical

Temperature Range		-40 °F to +176 °F [-40 °C to +80 °C]
Terminal Cross Section Multi-strand (max.)		12 AWG
		4 mm ² , 2.5 mm ² Q Version
Terminal Screw Torque		4.5 lbf-in [0.5 Nm]
Degree of Protection IEC/EN 60529		IP 20 (built-in)
Housing Material		Thermoplastic; Grey; Extinguishing Degree V-0
Mounting IEC/EN 60715		35mm DIN Rail

Order Information

Order Code		30
SPH-2-xxx		7082.84
SPH-2-xxxQ (Quick Connect Terminals)		7085.25
SPH-2-xxxM (module)		7082.85

RayDat SPH-2 Series

Internal Configuration

Legend

- DB Diode Block
- GDT Gas Discharge Tube
- PG Protective Grounding
- R Resistor
- TC Thermo-clip

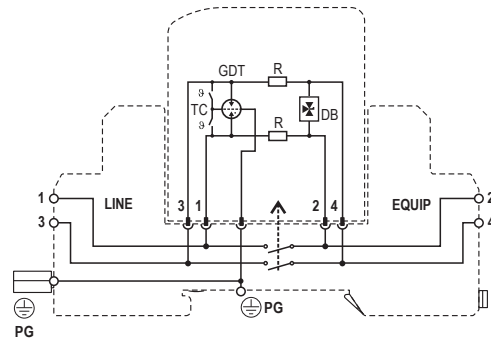

SPH-2-30

Dimensions & Packaging

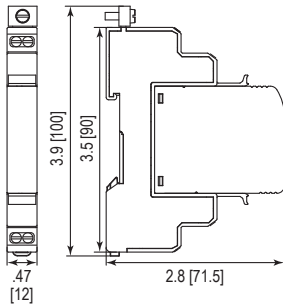

SPH-2 Series

30

Dimensions

Weight per Unit	1.83 oz [52 g]
Dimensions DIN 43880	2/3 TE
Packaging Dimensions (Single Unit)	3.4 x .59 x 4" [87 x 15 x 102 mm]
Minimum Package Quantity	15 pieces

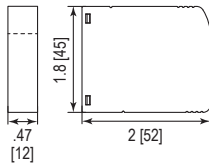

SPH-2-xxxM Series

30

Dimensions

Weight per Unit	.84 oz [24 g]
Packaging Dimensions (Single Unit)	3.4 x .59 x 4" [87 x 15 x 102 mm]
Minimum Package Quantity	15 pieces

Quick Connect Terminals

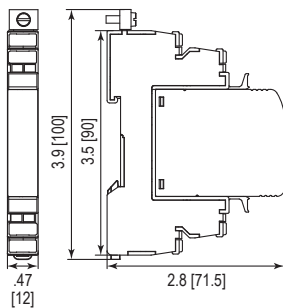

SPH-2-xxxQ Series

30

Dimensions

Weight per Unit	1.9 oz [54 g]
Dimensions DIN 43880	2/3 TE
Packaging Dimensions (Single Unit)	3.4 x .59 x 4" [87 x 15 x 102 mm]
Minimum Package Quantity	15 pieces

inches
[mm]



Modular SPD for Two Pair

RayDat SPH-4 Series

D1 • C1 • C2 • C3

UL Listed



IEC/EN Category: D1/C1/C2/C3
 Surge Discharge Ratings: I_n : 10 kA, I_{max} : 20 kA, I_{imp} : 5 kA
 Voltages: 30V DC
 Frequency Range: 30 MHz
 Housing: Modular Design
 Compliance: IEC/EN 61643-21
 UL 497B 4th Edition

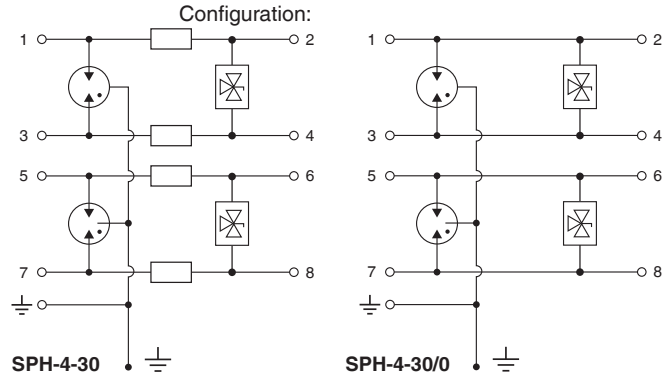

Technical Data

SPH-4 Series

Electrical

		2 (4 Conductors)	
Lines Protected		2 (4 Conductors)	
Nominal Operating Voltage (DC)	U_n	30V	
Maximum Continuous Operating Voltage (DC)	U_c	33V	
Rated Load Current at 25°C	I_L	1 A	10 A
C2 Nominal Discharge Current (8/20 μ s)	I_n	10 kA	
Maximum Discharge Current (8/20 μ s)	I_{max}	20 kA	
D1 Impulse Current (10/350 μ s)	I_{imp}	5 kA	
Residual Voltage at 5 kA (8/20 μ s)	(Line-Line) U_{res}	< 80V	
Rated Spark Overvoltage	(Line-Ground)	184-276V	
	(Line-Line)	36-44V	
Response Time Overvoltage Protection	(Line-Line) t_A	< 1 ns	
	(Line-Ground)	< 100 ns	
Insulation Resistance of the Protection	(Line-Ground) R_{iso}	> 1 G Ω /100V	
	(Line-Line)	\geq 33 M Ω	
Serial Resistance per Path	R	1.6-2.0 Ω	0.1 Ω
Transverse Capacitance	(Line-Line) C	50 pF	
	(Line-Ground)	5 pF	
Cut-off Frequency	f_G	30 MHz	

Mechanical

Temperature Range	-40 °F to +176 °F [-40 °C to +80 °C]		
Terminal Cross Section Multi-strand (max.)	12 AWG		
	4 mm ² , 2.5 mm ² Q Version		
Terminal Screw Torque	4.5 lbf-in [0.5 Nm]		
Degree of Protection IEC/EN 60529	IP 20 (built-in)		
Housing Material	Thermoplastic; Grey; Extinguishing Degree V-0		
Mounting IEC/EN 60715	35mm DIN Rail		

Order Information

Order Code	30	30/0
SPH-4-xx	7082.82	7086.89
SPH-4-xxQ (Quick Connect Terminals)	7085.24	7085.28
SPH-4-xxM (module)	7082.83	7085.29

RayDat SPH-4 Series

Internal Configuration

- Legend**
- DB Diode Block
 - GDT Gas Discharge Tube
 - PG Protective Grounding
 - R Resistor
 - TC Thermo-clip

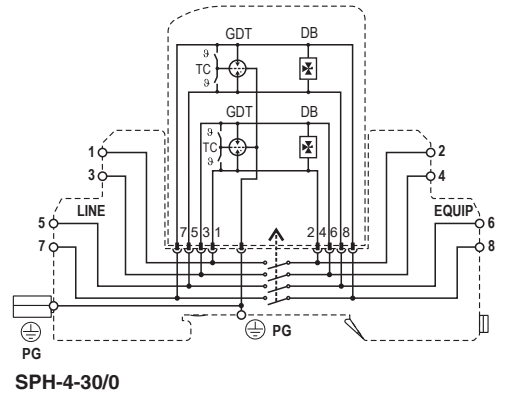
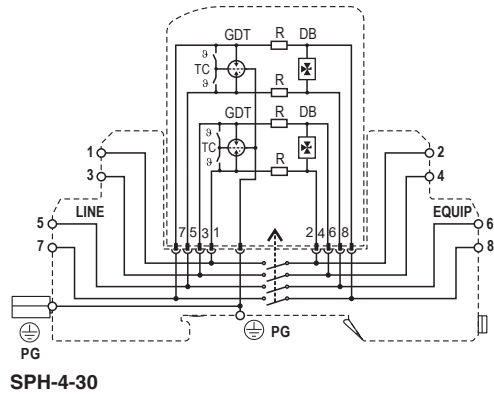

Dimensions & Packaging

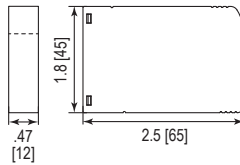
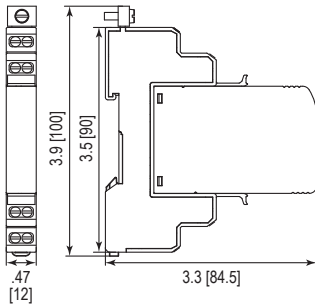

SPH-4 Series	30	30/0
Dimensions		
Weight per Unit	2.32 oz [66g]	2.25 oz [64g]
Dimensions DIN 43880	2/3 TE	
Packaging Dimensions (Single Unit)	3.4 x .59 x 4" [87 x 15 x 102 mm]	
Minimum Package Quantity	15 pieces	

SPH-4-xxM Series	30	30/0
Dimensions		
Weight per Unit	1.05 oz [30g]	.99 oz [28g]
Packaging Dimensions (Single Unit)	3.4 x .59 x 4" [87 x 15 x 102 mm]	
Minimum Package Quantity	15 pieces	

Quick Connect Terminals

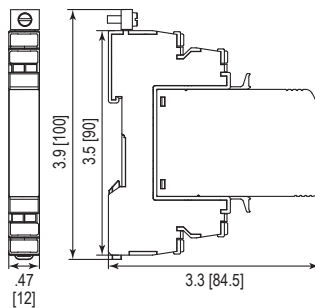

SPH-4-xxQ Series	30	30/0
Dimensions		
Weight per Unit	2.40 oz [68g]	2.32 oz [66g]
Dimensions DIN 43880	2/3 TE	
Packaging Dimensions (Single Unit)	3.4 x .59 x 4" [87 x 15 x 102 mm]	
Minimum Package Quantity	15 pieces	

inches
[mm]



Modular SPD for Two Pair RayDat SPI-2 Series D1 • C1 • C2 • C3



IEC/EN Category: D1/C1/C2/C3
 Surge Discharge Ratings: I_n : 10 kA, I_{max} : 20 kA, I_{imp} : 2.5 kA
 Voltages: 30 V DC
 Frequency Range: 30 MHz, 10 MHz
 Housing: Modular Design
 Compliance: IEC/EN 61643-21
 Configuration:

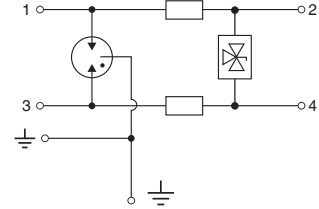

Technical Data

SPI-2 Series

30

Electrical

Lines Protected		1 (2 Conductors)
Nominal Operating Voltage (DC)	U_n	30V
Maximum Continuous Operating Voltage (DC)	U_c	33V
Rated Load Current at 25°C	I_L	1 A
C2 Nominal Discharge Current (8/20 μs)	I_n	10 kA
Maximum Discharge Current (8/20 μs)	I_{max}	20 kA
D1 Impulse Current (10/350 μs)	I_{imp}	2.5 kA
Total Impulse Current (10/350 μs)	I_{imp}	5 kA
Residual Voltage at 5 kA (8/20 μs)	(Line-Line) U_{res}	< 80V
Rated Spark Overvoltage	(Line-Ground)	184-276V
	(Line-Line)	36-44V
Response Time Overvoltage Protection	(Line-Line) t_A	< 1 ns
	(Line-Ground)	< 100 ns
Insulation Resistance of the Protection	(Line-Ground) R_{iso}	> 1 GΩ/100V
	(Line-Line)	≥ 33 MΩ
Serial Resistance per Path	R	1.6-2.0 Ω
Transverse Capacitance	(Line-Line) C	50 pF
	(Line-Ground)	5 pF
Cut-off Frequency	f_G	30 MHz

Mechanical

Temperature Range		-40 °F to +176 °F [-40 °C to +80 °C]
Terminal Cross Section Multi-strand (max.)		12 AWG
		4 mm ² , 2.5 mm ² Q Version
Terminal Screw Torque		4.5 lbf-in [0.5 Nm]
Degree of Protection IEC/EN 60529		IP 20 (built-in)
Housing Material		Thermoplastic; Grey; Extinguishing Degree V-0
Mounting IEC/EN 60715		35 mm DIN Rail

Order Information

Order Code		30
SPI-2-xxx		7085.67
SPI-2-xxxM (module)		7085.68

RayDat SPI-2 Series

Legend

- DB Diode Block
- GDT Gas Discharge Tube
- PG Protective Grounding
- R Resistor

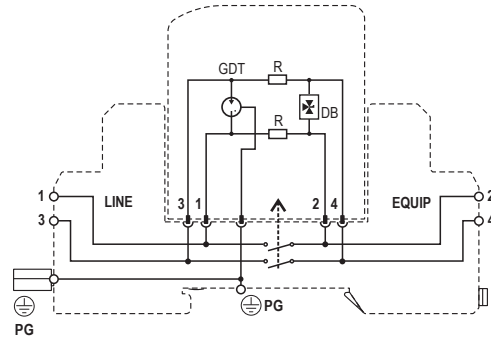

Dimensions & Packaging

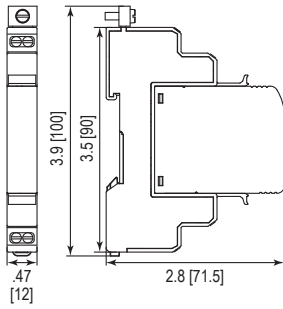

SPI-2 Series

30

Dimensions

Weight per Unit	1.90 oz [54 g]
Dimensions DIN 43880	2/3 TE
Packaging Dimensions (Single Unit)	3.4 x .59 x 4" [87 x 15 x 102 mm]
Minimum Package Quantity	15 pieces

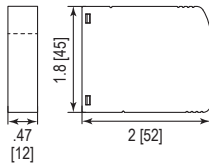

SPI-2-xxxM Series

30

Dimensions

Weight per Unit	.84 oz [24 g]
Packaging Dimensions (Single Unit)	3.4 x .59 x 4" [87 x 15 x 102 mm]
Minimum Package Quantity	15 pieces

inches
[mm]

Modular SPD for Two Pair

RayDat SPI-4 Series

D1 • C1 • C2 • C3



IEC/EN Category: D1/C1/C2/C3
 Surge Discharge Ratings: I_n : 10 kA, I_{max} : 20 kA, I_{imp} : 2.5 kA
 Voltages: 30 V DC
 Frequency Range: 30 MHz, 10 MHz
 Housing: Modular Design
 Compliance: IEC/EN 61643-21
 Configuration:

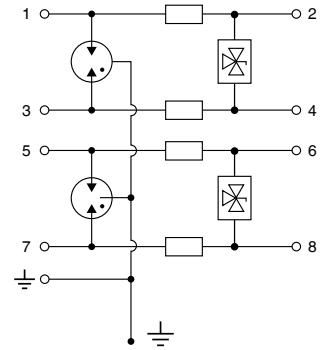

Technical Data

SPI-4 Series

30

Electrical

Lines Protected		2 (4 Conductors)
Nominal Operating Voltage (DC)	U_n	30V
Maximum Continuous Operating Voltage (DC)	U_c	33V
Rated Load Current at 25°C	I_L	1 A
C2 Nominal Discharge Current (8/20 μ s)	I_n	10 kA
Maximum Discharge Current (8/20 μ s)	I_{max}	20 kA
D1 Impulse Current (10/350 μ s)	I_{imp}	2.5 kA
Total Impulse Current (10/350 μ s)	I_{imp}	10 kA
Residual Voltage at 5 kA (8/20 μ s)	(Line-Line) U_{res}	< 80V
Rated Spark Overvoltage	(Line-Ground)	184-276V
	(Line-Line)	36-44V
Response Time Overvoltage Protection	(Line-Line) t_A	< 1 ns
	(Line-Ground)	< 100 ns
Insulation Resistance of the Protection	(Line-Ground) R_{iso}	> 1 G Ω /100V
	(Line-Line)	\geq 33 M Ω
Serial Resistance per Path	R	1.6-2.0 Ω
Transverse Capacitance	(Line-Line) C	50 pF
	(Line-Ground)	5 pF
Cut-off Frequency	f_G	30 MHz

Mechanical

Temperature Range		-40 °F to +176 °F [-40 °C to +80 °C]
Terminal Cross Section Multi-strand (max.)		12 AWG
		4 mm ² , 2.5 mm ² Q Version
Terminal Screw Torque		4.5 lbf-in [0.5 Nm]
Degree of Protection IEC/EN 60529		IP 20 (built-in)
Housing Material		Thermoplastic; Grey; Extinguishing Degree V-0
Mounting IEC/EN 60715		35 mm DIN Rail

Order Information

Order Code		30
SPI-4-xxx		7085.69
SPI-4-xxxM (module)		7085.70

RayDat SPI-4 Series

Legend

- DB Diode Block
- GDT Gas Discharge Tube
- PG Protective Grounding
- R Resistor

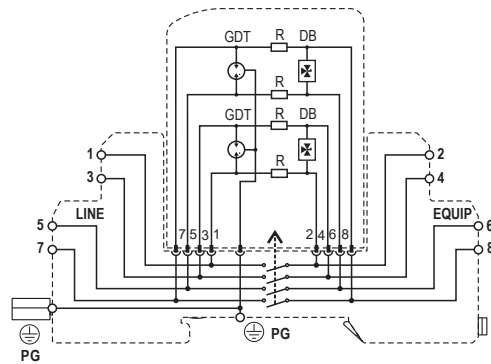

Dimensions & Packaging

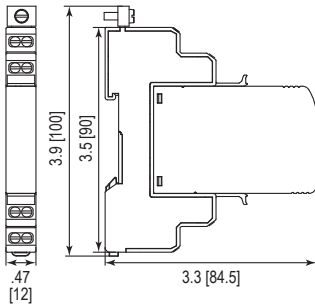

SPI-4 Series

30

Dimensions

Weight per Unit	2.40 oz [68g]
Dimensions DIN 43880	2/3 TE
Packaging Dimensions (Single Unit)	3.4 x .59 x 4" [87 x 15 x 102mm]
Minimum Package Quantity	15 pieces

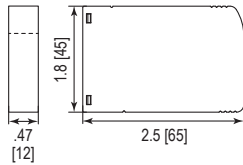

SPI-4-xxM Series

30

Dimensions

Weight per Unit	1.05 oz [30g]
Packaging Dimensions (Single Unit)	3.4 x .59 x 4" [87 x 15 x 102mm]
Minimum Package Quantity	15 pieces

inches
[mm]



Modular Surge Protective Devices (SPDs) for Data & Signal Lines



RayDat SRH Series

RayDat SRH-2*
RayDat SRH-2L*

*UL Listed

Special features:

- Very high surge ratings
- The connection lines remain enabled during module replacement
- Version available with potential free contact for fault detection
- Version available with LED visual indication for fault detection



Symbol Legend:



DIN Rail Mounting



Screw Connect Terminals



Quick Connect Terminals



Modular design



Shield Directly Grounded

These efficient overvoltage barriers contain both, coarse and fine protection stages and provide longitudinal and a transverse surge protection.

These products also feature an additional set of voltage free contacts which can be used for remote signalization and monitoring of the device's status. If the unit fails, the contacts change state.

The initial protection stage comprises a three-pole gas discharge tube (GDT) and is designed to divert the primary surge energy. The subsequent fine protection stage is carried out using fast bi-directional silicon avalanche diodes (SAD).

The design of the fine protection stage enables the product to avoid capacitive line loading and ensures a low insertion loss and wide operating frequency range.

Series line impedances ensure energy coordination between the coarse and a fine protection stages at all levels of a surge incident. To protect against the hazards of electric shock and fire, which often results when power frequency contact occurs between power and communication lines, often called mains incursion, a thermo-clip is included on the primary protection stage to divert the power frequency current to ground.



SPD with Remote Contacts

RayDat SRH-2 Series

D1 • C1 • C2 • C3

*UL Listed



IEC/EN Category: D1/C1/C2/C3
 Surge Discharge Ratings: I_n : 10 kA, I_{max} : 20 kA, I_{imp} : 2.5 kA
 Voltages: 5*, 12*, 15, 24*, 30*, 48, 60V DC
 Frequency Range: 30 MHz
 Housing: Modular Design
 Compliance: IEC/EN 61643-21
 UL 497B 4th Edition

Configuration:

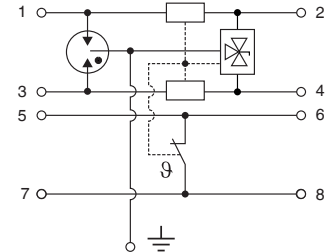

Technical Data

SRH-2 Series		5*	12*	15	24*	30*	48	60
Electrical								
Lines Protected		1 (2 Conductors)						
Nominal Operating Voltage (DC)	U_n	5V	12V	15V	24V	30V	48V	60V
Maximum Continuous Operating Voltage (DC)	U_c	6V	15V	18V	28V	33V	52V	64V
Rated Load Current at 25°C	I_L	1 A						
C2 Nominal Discharge Current (8/20µs)	I_n	10 kA						
Maximum Discharge Current (8/20µs)	I_{max}	20 kA						
D1 Impulse Current (10/350µs)	I_{imp}	2.5 kA						
Residual Voltage at 5kA (8/20µs)	U_{res}	<22V	<42V	<48V	<70V	<80V	<140V	<160V
Rated Spark Overvoltage	(Line-Ground)	7-10V	16-21V	21-25V	31-37V	36-44V	57-69V	68-84V
	(Line-Line)	7-10V	16-21V	21-25V	31-37V	36-44V	57-69V	68-84V
Response Time Overvoltage Protection	t_A	<1 ns						
Thermal Protection		Yes						
Insulation Resistance of the Protection	R_{iso}	≥ 6 KΩ	≥ 15 MΩ	≥ 18 MΩ	≥ 28 MΩ	≥ 33 MΩ	≥ 52 MΩ	≥ 64 MΩ
Serial Resistance per Path	R	1.6-2.0Ω						
Transverse Capacitance	C	50 pF						
Cut-off Frequency	f_G	30 MHz						
Mechanical								
Temperature Range		-40 °F to +176 °F [-40 °C to +80 °C]						
Terminal Cross Section Multi-strand (max.)		12 AWG [4 mm ² , 2.5 mm ² Q Version]						
Terminal Screw Torque		4.5 lbf-in [0.5 Nm]						
Degree of Protection IEC/EN 60529		IP20 (built-in)						
Housing Material		Thermoplastic; Grey; Extinguishing Degree V-0						
Mounting IEC/EN 60715		35 mm DIN Rail						
Remote Contacts Ratings		AC 250V/0.5A, DC 50V/1A						
Order Information								
Order Code		5*	12*	15	24*	30*	48	60
SRH-2-xxx		7086.17	7086.18	7086.19	7086.20	7086.21	7086.22	7086.23
SRH-2-xxxQ (Quick Connect Terminals)		7085.33	7085.34	7085.35	7085.36	7085.37	7085.38	7085.39
SRH-2-xxxM (module)		7086.25	7086.26	7086.27	7086.28	7086.29	7086.30	7086.31

RayDat SRH-2 Series

Internal Configuration

Legend

- DB Diode Block
- GDT Gas Discharge Tube
- PG Protective Grounding
- R Resistor
- RC Remote Control (NC)
- TC Thermo-clip

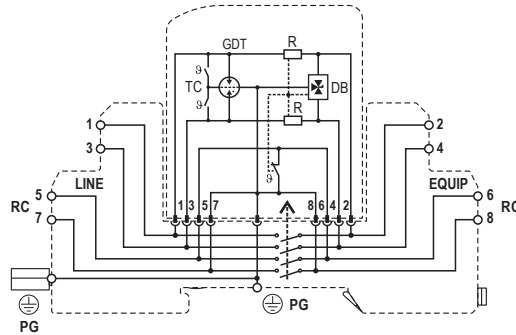

Dimensions & Packaging

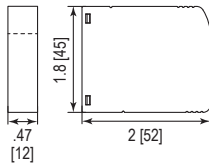
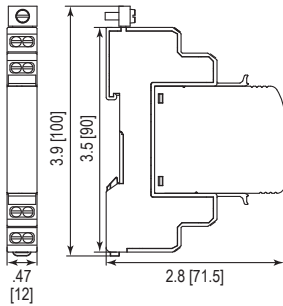

SRH-2 Series	5	12	15	24	30	48	60
Dimensions							
Weight per Unit	2.04 oz [58 g]						
Dimensions DIN 43880	2/3 TE						
Packaging Dimensions (Single Unit)	3.4 x .59 x 4" [87 x 15 x 102 mm]						
Minimum Package Quantity	15 pieces						

SRH-2-xxxM Series	5	12	15	24	30	48	60
Dimensions							
Weight per Unit	.84 oz [24 g]						
Packaging Dimensions (Single Unit)	3.4 x .59 x 4" [87 x 15 x 102 mm]						
Minimum Package Quantity	15 pieces						

Quick Connect Terminals

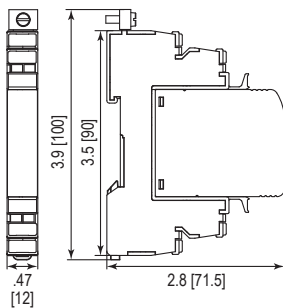

SRH-2-xxxQ Series	5	12	15	24	30	48	60
Dimensions							
Weight per Unit	2.11 oz [60 g]						
Dimensions DIN 43880	2/3 TE						
Packaging Dimensions (Single Unit)	3.4 x .59 x 4" [87 x 15 x 102 mm]						
Minimum Package Quantity	15 pieces						

inches
[mm]



SPD with Visual Indication
RayDat SRH-2L Series
D1 • C1 • C2 • C3

UL Listed



IEC/EN Category: D1/C1/C2/C3
 Surge Discharge Ratings: I_n : 10 kA, I_{max} : 20 kA, I_{imp} : 2.5 kA
 Voltages: 5, 12, 24, 30V DC
 Frequency Range: 30 MHz
 Housing: Modular Design
 Compliance: IEC/EN 61643-21
 UL 497B 4th Edition

Configuration:

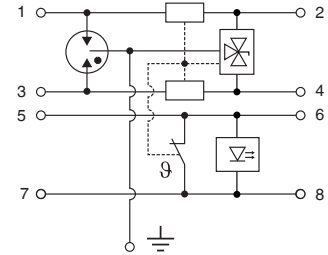

Technical Data

SRH-2L Series	5	12	24	30	
Electrical					
Lines Protected	1 (2 Conductors)				
Nominal Operating Voltage (DC)	U_n	5V	12V	24V	30V
Maximum Continuous Operating Voltage (DC)	U_c	6V	15V	28V	33V
Rated Load Current at 25°C	I_L	1 A			
C2 Nominal Discharge Current (8/20µs)	I_n	10 kA			
Maximum Discharge Current (8/20µs)	I_{max}	20 kA			
D1 Impulse Current (10/350µs)	I_{imp}	2.5 kA			
Residual Voltage at 5kA (8/20µs)	U_{res}	<22V	<42V	<70V	<80V
Rated Spark Overvoltage	(Line-Ground)	7-10V	16-21V	31-37V	36-44V
	(Line-Line)	7-10V	16-21V	31-37V	36-44V
Response Time Overvoltage Protection	t_A	<1 ns			
Thermal Protection		Yes			
Insulation Resistance of the Protection	R_{iso}	≥ 6 KΩ	≥ 15 MΩ	≥ 28 MΩ	≥ 33 MΩ
Serial Resistance per Path	R	1.6-2.0 Ω			
Transverse Capacitance	C	50 pF			
Cut-off Frequency	f_G	30 MHz			
Mechanical					
Temperature Range		-40 °F to +176 °F [-40 °C to +80 °C]			
Terminal Cross Section Multi-strand (max.)		12 AWG [4 mm ²]			
Terminal Screw Torque		4.42 lbf-in [0.5 Nm]			
Degree of Protection IEC/EN 60529		IP20 (built-in)			
Housing Material		Thermoplastic; Grey; Extinguishing Degree V-0			
Mounting IEC/EN 60715		35mm DIN Rail			
Remote Contacts Ratings		AC 250V/0.5A, DC 50V/1A			
Order Information					
Order Code	5	12	24	30	
SRH-2-xxxL	7085.44	7085.46	7085.48	7085.42	
SRH-2-xxxLM (module)	7085.45	7085.47	7085.49	7085.43	
SRH-2-xxxLQ	7085.56	7085.58	7085.60	7085.62	

RayDat SRH-2L Series

Internal Configuration

Legend

- DB Diode Block
- GDT Gas Discharge Tube
- PG Protective Grounding
- R Resistor
- RC Remote Control (NC)
- TC Thermo-clip

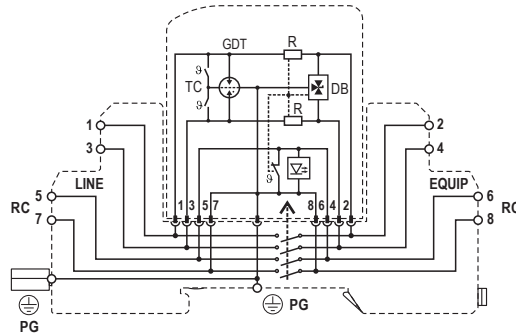

Dimensions & Packaging

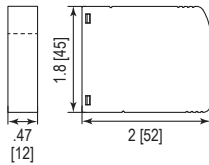
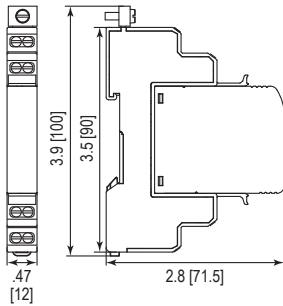

SRH-2L Series	5	12	24	30
Dimensions				
Weight per Unit	2.04 oz [58 g]			
Dimensions DIN 43880	2/3 TE			
Packaging Dimensions (Single Unit)	3.4 x .59 x 4" [87 x 15 x 102 mm]			
Minimum Package Quantity	15 pieces			

SRH-2-xxxLM Series	5	12	24	30
Dimensions				
Weight per Unit	.85 oz [24 g]			
Packaging Dimensions (Single Unit)	3.4 x .59 x 4" [87 x 15 x 102 mm]			
Minimum Package Quantity	15 pieces			

Quick Connect Terminals

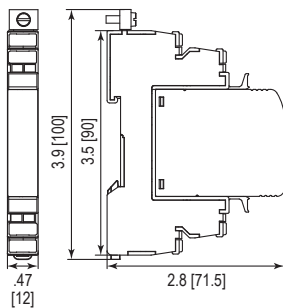

SRH-2LQ Series	5	12	24	30
Dimensions				
Weight per Unit	2.11 oz [60 g]			
Dimensions DIN 43880	2/3 TE			
Packaging Dimensions (Single Unit)	3.4 x .59 x 4" [87 x 15 x 102 mm]			
Minimum Package Quantity	15 pieces			

inches
[mm]



SPD with Visual Indication
RayDat SRH-2L Accessories
 D1 • C1 • C2 • C3

RayDat PSU-14



RayDat PSU-14 127 621

Electrical		
Input Voltage	U_{out}	21.5V DC ... 28V DC
Output Voltage		max. 28V DC
Output Current	I_{out}	2x2mA
Input Terminals		3 (+), 1 (-)

RayDat PSU-PB-7P

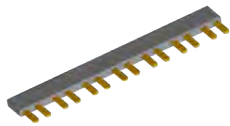

RayDat PSU-PB-7P 127 622

Electrical	
Number of Poles	7

RayDat PSU-PB-6P

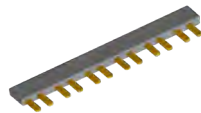

RayDat PSU-PB-6P 127 623

Electrical	
Number of Poles	6

Surge Protective Devices
(SPDs) for Explosive Environments



Ex Protection







RayDat Ex-2
RayDAT PLP Ex
RayDAT PLP2 Ex
RayDAT PLP-24/5 Ex
RayDAT PLP3L Ex

Special features:

- Very high surge ratings
- High density – up to 4 protected lines
- Version for DIN rail mounting available
- Version in metal (Stainless steel) housing available



Symbol Legend:

-  *DIN Rail Mounting*
-  *Screw Connect Terminals*
-  *Compact Design*
-  *Modular Design*
-  *Wire Connection*
-  *Shield Directly Grounded*
-  *Ex Certificate*

The RayDat Ex Series is intended to provide protection to low voltage signal and data circuits, located in potentially explosive environments.

It is intended for use on inherently safe circuits in accordance with the ATEX directive. The protection module should be located as close as possible to the end-user equipment being protected. The circuit consists of a multi-stage protector providing both, common (longitudinal) mode and differential (transverse) mode protection.

Coarse protection is provided using a three terminal gas discharge tube (GDT), while fine protection is provided using a high-speed bi-directional silicon stage. Care is taken between these two stages to ensure coordination without voltage or surge current blind spots occurring.



SPD for Explosive Environments

RayDat Ex-2 Series

D1 • C1 • C2 • C3



IEC/EN Category: D1/C1/C2/C3
 Surge Discharge Ratings: I_{n1} : 5 kA, I_{max} : 10 kA, I_{imp} : 1 kA
 Voltages: 12, 24 V DC

Max. Operating Voltage: U_c : 15, 28 VDC

Terminals: Stranded to 4 mm²

Housing: Modular Design

Compliance: IIEC/EN 61643-21

IEC 60079-0:2011

IEC 60079-11:2011

EN 60079-0:2012+A11:2013

EN 60079-11:2012

Configuration:

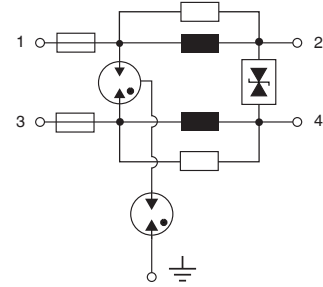

	Input Power P_i	Temperature Class	Maximum Ambient
$U_o = U_i$	$P_i = 1W$	T6	50 °C
$I_o = I_i$	$P_i = 1.3W$	T5	55 °C
$P_o = P_i$	$P_i = 2W$	T4	60 °C

Technical Data

Ex-2 Series	12	24
Type		
Intrinsic Safety Parameters		
Explosion Protected	II 1G Ex ia IIC T* Ga (-40 °C ≤ Ta ≤ +°C)	
Maximum Input Voltage	U_i 16V	29V
Maximum Input Current	I_i 500 mA	
Maximum Input Power	P_i 2W	
Maximum Internal Capacitance	C_i 10 nF	
Maximum Internal Inductance	L_i 0.11 mH	
Number of Protected Pairs	1 (2 Conductors)	
Electrical		
Nominal Operating Voltage (DC)	U_n 12V	24V
Maximum Continuous Operating Voltage (DC)	U_c 15V	28V
Rated Load Current at 25°C	I_L 500 mA	
Nominal Discharge Current (8/20 μs)	I_n 5 kA	
Maximum Discharge Current (8/20 μs)	I_{max} 10 kA	
D1 Impulse Current (10/350 μs)	I_{imp} 1 kA	
Residual Voltage at 5 kA (8/20 μs)	U_{res} < 145V	
Rated Spark Overvoltage (Line-Line)	16-21V	31-37V
(Line-Ground)	584-876V	
Response Time Overvoltage Protection	t_A < 1 ns	
Insulation Resistance at U_c	R_{iso} ≥ 15 MΩ	≥ 28 MΩ
Insulation Resistance at 500VDC (Line-Ground)	> 1 GΩ	
Serial Resistance per Path	R < 1 Ω	
Transverse Capacitance	C < 10 pF	
Cut-off Frequency	f_G 3 MHz	
Mechanical		
Terminal Cross Section Multi-strand (max.)	12 AWG [4 mm ²]	
Terminal Screw Torque	4.5 lbf-in [0.5 Nm]	
Degree of Protection IEC/EN 60529	IP 20 (built-in)	
Housing Material	Thermoplastic; Grey; Extinguishing Degree V-0	
Mounting IEC/EN 60715	35mm DIN Rail	
Order Information		
Order Code	12	24
Ex-2-xx	704 120	704 121

RayDat Ex-2 Series

Internal Configuration

Legend

- DB Diode Block
- F Fuse
- GDT Gas Discharge Tube
- L Inductor
- PG Protective Grounding
- R Resistor

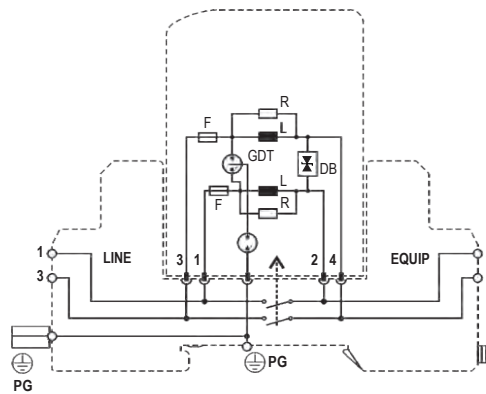

Dimensions & Packaging

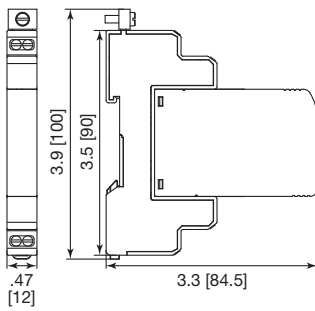

Ex-2 Series	12	24
Dimensions		
Weight per Unit	3.10 oz [88g]	
Dimensions DIN 43880	2/3 TE	
Packaging Dimensions (Single Unit)	3.4 x .59 x 4" [87 x 15 x 102mm]	
Minimum Package Quantity	15 pieces	

inches
[mm]

SPD for Explosive Environments

RayDat PLP Ex Series

D1 • C1 • C2 • C3



IEC/EN Category: D1/C1/C2/C3
 Surge Discharge Ratings: I_{nt} : 10kA, I_{max} : 20kA, I_{imp} : 2.0kA
 Voltages: 24, 48, 24/5V DC
 Max. Operating Voltage: U_c : 33, 54, 33/7.5V DC
 Frequency Range: 30 MHz

Enclosure: Stainless Steel IP54
 Terminals: Connecting Cables 1 mm²,
 250mm length
 Housing: Conduit Fitting
 Compliance: IEC/EN 61643-21



IEC 60079-0:2011
 IEC 60079-11:2011
 EN 60079-0:2012+A11:2013
 EN 60079-11:2012



UL 60079-0, 6th Edition
 UL 60079-11, 6th Edition
 CAN/CSA C22.2 No. 60079-0:2015
 CAN/CSA C22.2 No. 60079-11:2014



Technical Data

PLPEx	PLP2-24Ex	PLP2-24Ex	PLP2-48Ex	PLP2-24/5Ex	PLP3L-24Ex	
Type						
Intrinsic Safety Parameters						
IECEX BAS 14.0167X	Ex ia IIC T6 Ga (-30°C ≤ 50°C), Ex ia IIIC T85°C Da (-30°C ≤ 50°C)					
Basefa14ATEX0364X	II 1G Ex ia IIC T6 Ga (-30°C ≤ 50°C), II 1D Ex ia IIIC T85°C Da (-30°C ≤ 50°C)					
SGSNA/18/BAS/00003	Class I, Zone 0 AEx ia IIC T6 Ga (-30°C ≤ 50°C), Ex ia IIC T6 Ga (-30°C ≤ 50°C), Zone 20 AEx ia IIIC T85°C Da (-30°C ≤ 50°C), Ex ia IIIC T85°C Da (-30°C ≤ 50°C)					
Maximum Input Voltage	U_i	50V				
Maximum Input Current	I_i	800mA				
Maximum Input Power	P_i	2W				
Maximum Internal Inductance	L_i	60µH				
Electrical						
Nominal Operating Voltage (DC)	U_n	24V	24V	48V	24V/5V	24V
Maximum Continuous Operating Voltage (DC)	U_c	33V	33V	54V	33V/7.5V	33V
Rated Spark Overvoltage	(Line-Ground)	584-864V	584-864V	584-864V	584-864V	584-864V
	(Line-Line)	36-44V	36-44V	58-68V	36-44V, 9-13V	36-44V
Total Nominal Discharge Current (8/20µs)	I_n	5kA	10kA	10kA	10kA	7.5kA
Total Discharge Current (8/20µs)	I_{max}	10kA	20kA	20kA	20kA	15kA
Total Impulse Current (10/350µs)	I_{imp}	1.0kA	2.0kA	2.0kA	2.0kA	1.5kA
Residual Voltage at I_{max} (8/20µs)	(Line-Ground) U_{res}	<1.3kV	<1.3kV	<1.3kV	<1.3kV	<1.3kV
Response Time Overvoltage Protection	t_A	<1 ns				
Insulation Resistance of the Protection	(Line-Line) R_{iso}	> 32MΩ	> 32MΩ	> 32MΩ	> 32MΩ/75kΩ	> 32MΩ
Insulation Resistance at U (Line-Ground)=500VDC	R	> 1GΩ				
Transverse Capacitance	C	<30 pF				
Cut-off Frequency	f_G	30MHz				
Mechanical						
Ambient Temperature Range		-22 °F < T_a < +140 °F [-30 °C < T_a < +60 °C]				
Connection Cables	D × L	17 AWG × 9.8" [1 mm ² × 250 mm]				
Degree of Protection IEC/EN 60529		IP54				
Housing Material		Stainless Steel				
Dimension	Length	3.07" [78 mm]	4.72" [120 mm]	4.72" [120 mm]	4.72" [120 mm]	4.72" [120 mm]
Order Information						
Order Code		PLP2-24Ex	PLP2-24Ex	PLP2-48Ex	PLP2-24/5Ex	PLP3L-24Ex
1/2" NPT		127 594	127 600	127 597	127 603	127 606
M20 × 1.5		127 595	127 601	127 598	127 604	127 607
G 1/2" (BSP 1/2 inch)		127 596	127 602	127 599	127 605	127 608

RayDat PLP Ex Series

Internal Configuration

Legend
 DB Diode Block
 GDT Gas Discharge Tube

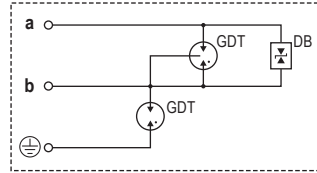

PLP-24Ex

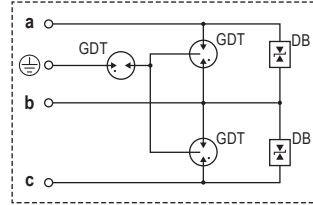

PLP3L-24Ex

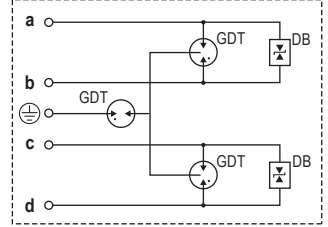

**PLP2-24Ex
 PLP2-48Ex
 PLP-24/5Ex**

Dimensions & Packaging

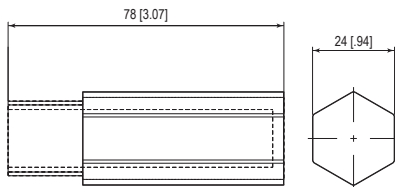

PLP-24Ex	PLP-24 Ex 1/2" NPT	PLP-24 Ex M 20 x 1/2"	PLP-24 Ex G 1/2"
Dimensions			
Weight per Unit	5.99 oz [170 g]		
Packaging Dimensions (Single Unit)	1.34 x 1.34x 4.25" [34 x 34 x 108 mm]		
Minimum Package Quantity	6 pieces		

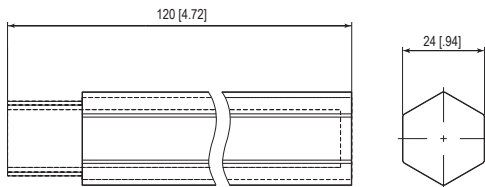

PLP2-xxEx	PLP2-xx Ex 1/2" NPT	PLP2-xx Ex M 20 x 1/2"	PLP2-xx Ex G 1/2"
Dimensions			
Weight per Unit	10.22 oz [290 g]		
Packaging Dimensions (Single Unit)	1.34 x 1.34x 5.43" [34 x 34 x 138 mm]		
Minimum Package Quantity	6 pieces		

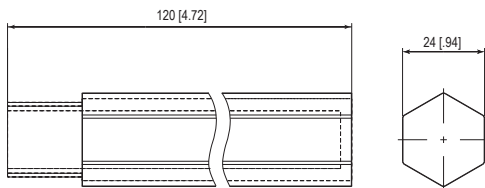

PLP3L-24Ex	PLP3L-24 Ex 1/2" NPT	PLP3L-24 Ex M 20 x 1/2"	PLP3L-24 Ex G 1/2"
Dimensions			
Weight per Unit	10.22 oz [290 g]		
Packaging Dimensions (Single Unit)	1.34 x 1.34x 5.43" [34 x 34 x 138 mm]		
Minimum Package Quantity	6 pieces		

inches
[mm]





Surge Protective Devices
(SPDs) for Local Area Networks (LAN)



Local Area Networks (LAN)

RayDat NET 6 POE*





*UL Listed

Special features:

- Very high surge ratings
- Metal housing with DIN rail mounting
- Cat 6 capability
- POE compliant in accordance to IEEE 802.3af, IEEE 802.3at and IEEE 802.3bt.



Symbol Legend:

-  DIN Rail Mounting
-  Plug-In Connection
-  Compact Design
-  Shield Directly Grounded

RayDat NET 6 POE is intended to protect Local Area Networks (LAN) from overvoltage surges and electrostatic discharges created by switching transients inside buildings. LAN systems are particularly prone to such disturbances due to long cable lengths since long cable lengths often behave like antennas to atmospheric disturbances. The product provides protection to all four lines

in the UTP, STP and is Cat 6 capable. Ground potential equalization between signal and protective network or PC chassis ground is provided. The product is suitable for protection of 1 Gbit/s lines and fully compatible with all versions of PoE applications. It is compatible with standards IEEE 802.3af, IEEE 802.3at and IEEE 802.3bt.



SPD for LAN Category 6 Networks
RayDat NET 6 POE
D1 • C1 • C2 • C3

UL Listed



IEC/EN Category: D1/C1/C2/C3
 Surge Discharge Ratings: I_n : 10kA, I_{imp} : 1kA
 Voltages: 48V DC
 Max. Operating Voltage: 50V
 Frequency Range: 250MHz, up to Cat 6,
 up to PoE++ Compatible
 Housing: Compact Design
 Compliance: IEC/EN 61643-21
 UL 497B 4th Edition



Technical Data

NET 6 POE

48

Electrical

Number of Protected Pairs		4 Pairs (8 Conductors)
Nominal Operating Voltage (DC)	U_n	48V
Maximum Continuous Operating Voltage (DC)	(Line-Line) U_c	50V
	(Pair-Pair)	72V
Rated Load Current at 25°C	I_L	1 A
Nominal Discharge Current (8/20 μ s)	(Line-Line) I_n	150A
C2 Total Discharge Current (8/20 μ s)	(Lines-Ground) I_n	10kA
D1 Impulse Current (10/350 μ s)	I_{imp}	1kA
Voltage Protection Level at I_n	(Line-Line) U_p	150V
	(Line-Ground)	550V
Response Time Overvoltage Protection	t_A	< 1 ns
Cut-off Frequency	f_G	250 MHz

Mechanical

Temperature Range	-40 °F to +176 °F [-40 °C to +80 °C]
Connection Type	Input/Output: RJ45 Sockets
Degree of Protection IEC/EN 60529	IP 20
Housing Material	Metal
Mounting IEC/EN 60715	35mm DIN Rail

Order Information

Order Code	48
NET 6 POE	706 312

RayDat NET 6 POE

Internal Configuration

Legend
 DB Diode Block
 GDT Gas Discharge Tube
 PG Protective Grounding

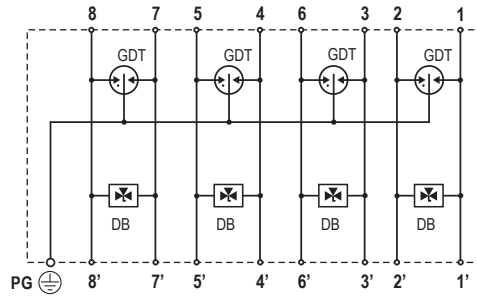

Dimensions & Packaging

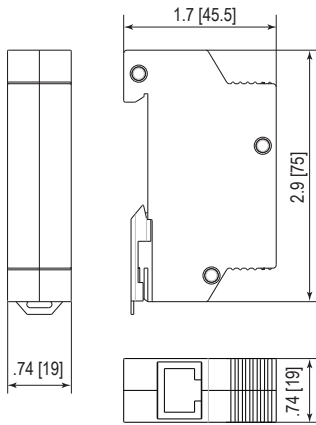

NET 6 POE

48

Dimensions

Weight per Unit	4.23 oz [120 g]
Dimensions DIN 43880	.74" [19 mm]
Packaging Dimensions (Single Unit)	3.1 x .91 x 4.3" [78 x 23 x 108 mm]
Minimum Package Quantity	12 pieces

inches
[mm]





Surge Protective Devices (SPDs) for Bus Systems



Bus Systems

Special features:





- Very high surge ratings
- Equipped with screw or quick connect (spring loaded) terminals
- Different shield handling options available
- The connection lines remain enabled during module replacement

RayDat SBH-3*
 RayDat SGH-3
 RayDat RS 485
 RayDat KNX

*UL Listed



Symbol Legend:

-  DIN Rail Mounting
-  Screw Connect Terminals
-  Quick Connect Terminals
-  Modular Design
-  Shield Indirectly Grounded

The RayDat SBH-3 Series of surge protective devices has been developed to protect fieldbus systems (CAN Bus, Profibus DP, RS 232/V.24 m, RS 485, Sinec L2). It is intended for those applications where high ground potential rises may frequently occur, such as in locations close to electric railways.

The RayDat RS 485 has been designed to protect all versions of RS 485. It can be used for protection of RS 422 and V.11 protocol as well.

Coarse protection is provided by a three terminal gas discharge tube (GDT), while fine protection is provided using a high-

speed silicon stage, which provides both, common (longitudinal) mode protection from each line to protective ground and differential (transverse) mode protection between each pair. Care is taken to ensure coordination between these two stages without voltage or surge current blind spots occurring. Thermal protection is provided to reduce the hazards of thermal runaway, should there be an inadvertent mains incursion fault.

RayDat KNX – has been designed to protect KNX systems. Its special design allows the protector to be installed directly to bus terminals.

Modular SPD for Industrial Fieldbus Systems

RayDat SBH-3 Series

D1 • C1 • C2 • C3

UL Listed



IEC/EN Category: D1/C1/C2/C3
 Surge Discharge Ratings: I_n : 10 kA, I_{max} : 20 kA, I_{imp} : 2.5 kA
 Voltages: 5, 12, 30V DC
 Frequency Range: 30 MHz
 Housing: Modular Design
 Compliance: IEC/EN 61643-21
 UL 497B 4th Edition

Configuration:

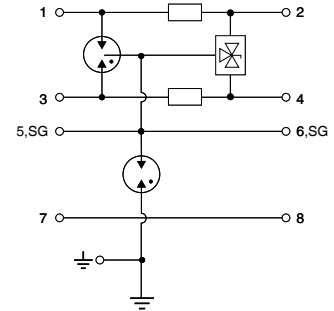

Technical Data

SBH-3 Series	5	12	30	
Electrical				
Lines Protected	1 (2 Conductors)			
Nominal Operating Voltage (DC)	U_n 5V	12V	30V	
Maximum Continuous Operating Voltage (DC)	U_c 6V	15V	33V	
Rated Load Current at 25°C	I_L	1 A		
C2 Nominal Discharge Current (8/20 μs)	I_n	10 kA		
Maximum Discharge Current (8/20 μs)	I_{max}	20 kA		
D1 Impulse Current (10/350 μs)	I_{imp}	2.5 kA		
Residual Voltage at 5 kA (8/20 μs)	(Line-Line) U_{res}	< 22V	< 42V	< 80V
Rated Spark Overvoltage	(SG-Ground)	184-276V		
	(Line-Line)	7-10V	16-19V	35-43V
Response Time Overvoltage Protection	(Line-Line) t_A	< 1 ns		
	(Line-Ground)	< 100 ns		
Insulation Resistance of the Protection	(Line-Ground) R_{iso}	> 1 GΩ/100V		
	(Line-Line)	≥ 6 KΩ	≥ 15 MΩ	≥ 33 MΩ
Serial Resistance per Path	R	1.6-2.0 Ω		
Transverse Capacitance	(Line-Line) C	50 pF		
	(Line-Ground)	5 pF		
Cut-off Frequency	f_G	30 MHz		
Mechanical				
Temperature Range	-40 °F to +176 °F [-40 °C to +80 °C]			
Terminal Cross Section Multi-strand (max.)	12 AWG			
	4 mm ² , 2.5 mm ² Q Version			
Terminal Screw Torque	4.5 lbf-in [0.5 Nm]			
Degree of Protection IEC/EN 60529	IP 20 (built-in)			
Housing Material	Thermoplastic; Grey; Extinguishing Degree V-0			
Mounting IEC/EN 60715	35 mm DIN Rail			
Order Information				
Order Code	5	12	30	
SBH-3-xx	7082.86	7082.88	7082.90	
SBH-3-xxQ (Quick Connect Terminals)	7085.21	7085.22	7085.23	
SBH-3-xxM (module)	7082.87	7082.89	7082.91	

RayDat SBH-3 Series

Internal Configuration

Legend

- DB Diode Block
- GDT Gas Discharge Tube
- PG Protective Grounding
- R Resistor
- SG Signal Grounding
- TC Thermo-clip

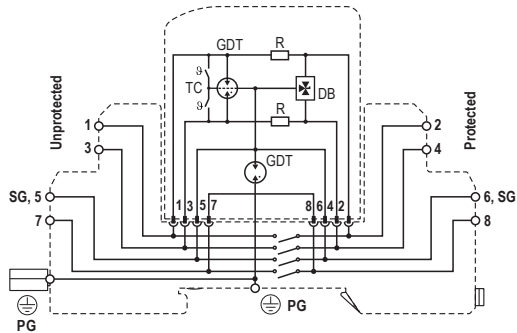

Dimensions & Packaging

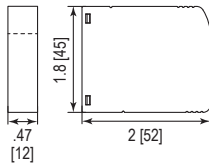
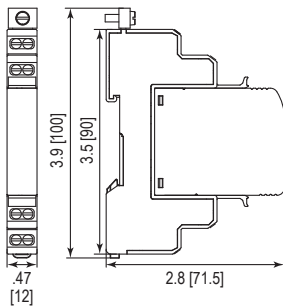

SBH-3 Series	5	12	30
Dimensions			
Weight per Unit	2.11 oz [60g]		
Dimensions DIN 43880	2/3 TE		
Packaging Dimensions (Single Unit)	3.4 x .59 x 4" [87 x 15 x 102 mm]		
Minimum Package Quantity	15 pieces		

SBH-3-xxM Series	5	12	30
Dimensions			
Weight per Unit	.91 oz [26g]		
Packaging Dimensions (Single Unit)	3.4 x .59 x 4" [87 x 15 x 102 mm]		
Minimum Package Quantity	15 pieces		

Quick Connect Terminals

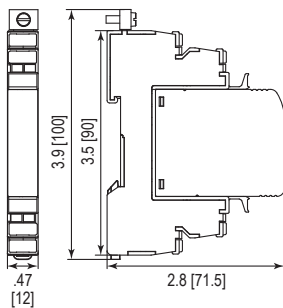

SBH-3-xxQ Series	5	12	30
Dimensions			
Weight per Unit	2.18 oz [62g]		
Dimensions DIN 43880	2/3 TE		
Packaging Dimensions (Single Unit)	3.4 x .59 x 4" [87 x 15 x 102 mm]		
Minimum Package Quantity	15 pieces		

inches
[mm]



SPD with Separated Signal Ground (RS 232)

RayDat SGH-3 Series

D1 • C1 • C2 • C3



IEC/EN Category: D1/C1/C2/C3
 Surge Discharge Ratings: I_n : 10kA, I_{max} : 20kA, I_{imp} : 2.5kA
 Voltages: 5, 12, 15, 24, 30, 48, 60, 110V DC
 Frequency Range: 30MHz
 Housing: Modular Design
 Compliance: IEC/EN 61643-21
 Configuration:

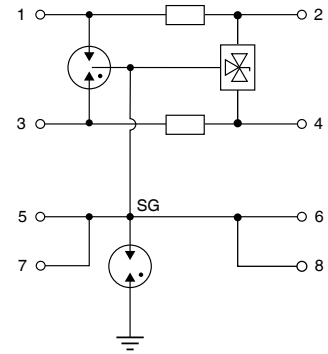

Technical Data

SGH-3 Series		5	12	15	24	30	48	60
Electrical								
Lines Protected		1 (2 Conductors)						
Nominal Operating Voltage (DC)	U_n	5V	12V	15V	24V	30V	48V	60V
Maximum Continuous Operating Voltage (DC)	U_c	6V	15V	18V	28V	33V	52V	64V
Rated Load Current at 25°C	I_L	1 A						
C2 Nominal Discharge Current (8/20µs)	I_n	10kA						
Maximum Discharge Current (8/20µs)	I_{max}	20kA						
D1 Impulse Current (10/350µs)	I_{imp}	2.5kA						
Residual Voltage at 5kA (8/20µs)	(Line-Line) U_{res}	<22V	<42V	<48V	<70V	<80V	<140V	<160V
Rated Spark Overvoltage	(SG-Ground)	184-276V						
	(Line-Line), (Line-SG)	7-10V	16-19V	20-24V	30-36V	35-43V	55-68V	67-85V
Response Time Overvoltage Protection	(Line-Line) t_A	< 1 ns						
	(Line-Ground)	< 100 ns						
Insulation Resistance of the Protection	(Line-Line) R_{iso}	≥ 6KΩ	≥ 15MΩ	≥ 18MΩ	≥ 28MΩ	≥ 33MΩ	≥ 52MΩ	≥ 64MΩ
	(Line-Ground)	> 1GΩ/100V						
Serial Resistance per Path	R	1.6-2.0Ω						
Transverse Capacitance	(Line-Line) C	50pF						
	(Line-Ground)	5pF						
Cut-off Frequency	f_G	30MHz						
Mechanical								
Temperature Range		-40 °F to +176 °F [-40 °C to +80 °C]						
Terminal Cross Section Multi-strand (max.)		12 AWG [4 mm ² , 2.5 mm ² Q Version]						
Terminal Screw Torque		4.5 lbf-in [0.5 Nm]						
Degree of Protection IEC/EN 60529		IP20 (built-in)						
Housing Material		Thermoplastic; Grey; Extinguishing Degree V-0						
Mounting IEC/EN 60715		35 mm DIN Rail						
Order Information								
Order Code		5	12	15	24	30	48	60
SGH-3-xxx		7086.61	7086.62	7086.63	7086.64	7086.65	7086.66	7086.67
SGH-3-xxxM (module)		7086.69	7086.70	7086.71	7086.72	7086.73	7086.74	7086.75

RayDat SGH-3 Series

Internal Configuration

Legend

- DB Diode Block
- GDT Gas Discharge Tube
- R Resistor
- PG Protective Grounding
- SG Signal Grounding
- TC Thermo-clip

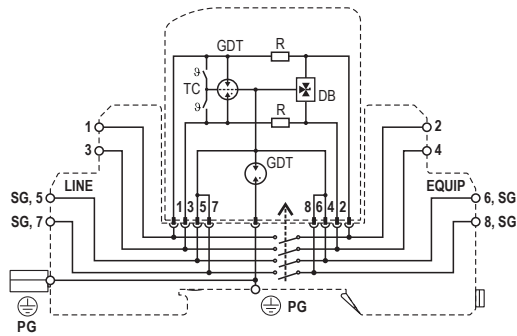

Dimensions & Packaging

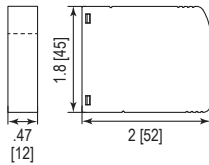
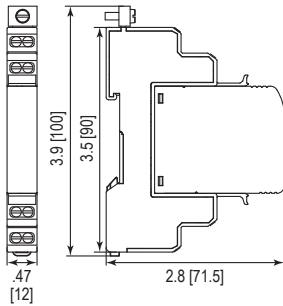

SGH-3 Series	5	12	15	24	30	48	60
Dimensions							
Weight per Unit	2.11 oz [60g]						
Dimensions DIN 43880	2/3 TE						
Packaging Dimensions (Single Unit)	3.4 x .59 x 4" [87 x 15 x 102mm]						
Minimum Package Quantity	15 pieces						

SGH-3-xxxM Series	5	12	15	24	30	48	60
Dimensions							
Weight per Unit	.91 oz [26g]						
Packaging Dimensions (Single Unit)	3.4 x .59 x 4" [87 x 15 x 102mm]						
Minimum Package Quantity	15 pieces						

inches
[mm]

SPD for RS-485 Systems
RayDat RS 485
D1 • C1 • C2 • C3



IEC/EN Category: D1/C1/C2/C3
 Surge Discharge Ratings: I_n : 20 kA, I_{imp} : 2.5 kA
 Voltages: 5VDC
 Max. Operating Voltage: 6VDC
 Frequency Range: 1 MHz
 Housing: 16 Terminal, Compact Design
 Compliance: IEC/EN 61643-21



Technical Data

RS 485

Electrical

Number of Protected Pairs		2(4 Conductors)
Nominal Operating Voltage (DC)	U_n	5V
Maximum Continuous Operating Voltage (DC)	U_c	6V
Rated Load Current at 25°C	I_L	500mA
C2 Nominal Discharge Current (8/20 μ s) (Line-Line)	I_n	20 kA
D1 Impulse Current (10/350 μ s)	I_{imp}	2.5 kA
Residual Voltage at 5 kA (8/20 μ s) (Line-Line)	U_{res}	20V
Rated Spark Overvoltage (5, 6, 7 & 8-4, SG)		6.5V – 8.5V
	(5-6 & 7-8)	6.5V – 8.5V
	(5,6,7 & 8-2, PG)	78V – 116V
Response Time Overvoltage Protection (5,6,7,8,SG)	t_A	< 1 ns
Thermal Protection (5,6,7,8)		Yes
Insulation Resistance of Protection	R_{iso}	6 k Ω
Serial Resistance per Path	R	1.7 – 1.9 Ω
Transverse Capacitance	C	< 2nF
Cut-off Frequency	f_G	> 1 MHz

Mechanical

Temperature Range		-40 °F to +176 °F [-40 °C to +80 °C]
Terminal Cross Section Multi-strand (max.)		2x14 AWG [2 x 2.5 mm ²]
Terminal Screw Torque		17.7 lbf.in [2.0 Nm]
Degree of Protection IEC/EN 60529		IP 20 (built-in)
Housing Material		Thermoplastic; Grey; Extinguishing Degree V-0
Mounting IEC/EN 60715		35mm DIN Rail

Order Information

Order Code		
RS 485		703 812

RayDat RS 485

Internal Configuration

Legend

- BD Bi-directional TVS Diode
- GDT Gas Discharge Tube
- PG Protective Grounding
- R Resistor
- SG Signal Grounding
- TC Thermo-clip

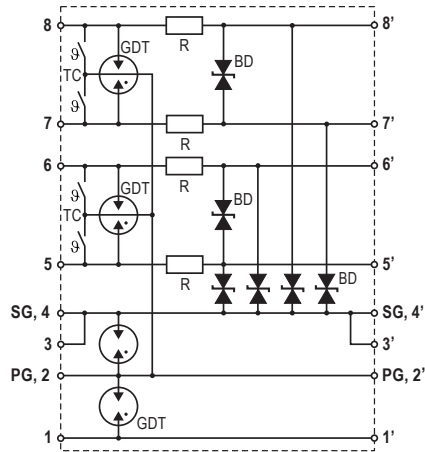

Dimensions & Packaging

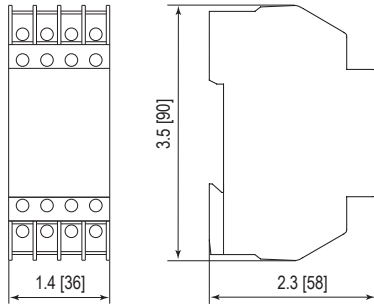

RS 485

Dimensions

Weight per Unit	4.02 oz [114 g]
Dimensions DIN 43880	2TE
Packaging Dimensions (Single Unit)	1.5 x 2.9 x 4.2" [39 x 74 x 106 mm]
Minimum Package Quantity	6 pieces

inches
[mm]

SPD with Terminal Connection for Bus Systems

RayDat KNX

D1 • C1 • C2 • C3

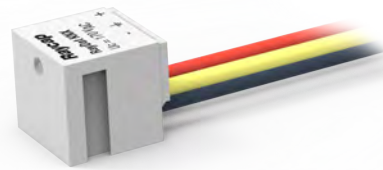

IEC/EN Category: D1/C1/C2/C3

Voltages: 24V AC

Max. Operating Voltage: 170V DC

Surge Discharge Ratings: I_n : 5 kA, I_{max} : 10 kA, I_{imp} : 1 kA

Series Load Current: 7 A

Housing: Compact Design

Compliance: IEC/EN 61643-21



Technical Data

RayDat KNX

Electrical

Number of Protected Pairs		1 (2 conductors)
Nominal Operating Voltage (AC)	U_n	24V
Maximum Continuous Operating Voltage (DC)	U_c	170V
Rated Load Current at 25°C	I_L	7 A
C2 Nominal Discharge Current (8/20 μ s)	I_n	5 kA
Maximum Discharge Current (8/20 μ s)	I_{max}	10 kA
D1 Impulse Current (10/350 μ s)	I_{imp}	1 kA
Residual Voltage at 5 kA (8/20 μ s)	(Line-Ground) U_{res}	< 600V
	(Line-Line)	< 1000V
Response Time Overvoltage Protection	t_A	< 100 ns
Thermal Protection		No
Insulation Resistance of the Protection	R_{iso}	$\geq 1 \text{ G}\Omega$
Serial Resistance per Path	R	< 0.1 Ω
Cut-off Frequency	f_G	50 MHz

Mechanical

Temperature Range		-40 °F to +176 °F [-40 °C to +80 °C]
Line Conductors Cross Section		20 AWG [0.5 mm ²]
Ground Conductor Cross Section		18 AWG [0.75 mm ²]
Connecting Conductor Length		7.9" [200 mm]
Degree of Protection IEC/EN 60529		IP20 (built-in)
Housing Material		Thermoplastic; Grey; Extinguishing Degree V-0

Order Information

Order Code		
RayDat KNX		127 649

RayDat KNX

Internal Configuration

Legend

- GDT Gas Discharge Tube
- PG Protective Grounding

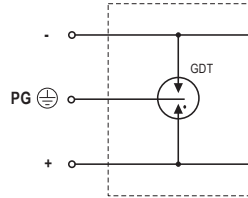

Dimensions & Packaging

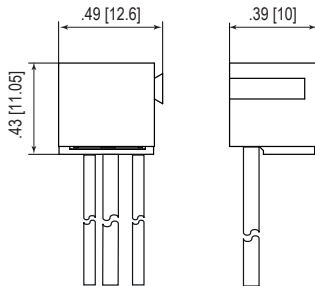

RayDat KNX

Dimensions

Weight per Unit	.28 oz [8 g]
Packaging Dimensions (Single Unit)	3.1 x .91 x .43" [78 x 23 x 108 mm]
Minimum Package Quantity	12 pieces

inches
[mm]





Modular & Compact Surge Protective Devices (SPDs) for Telecommunication Systems

Telecommunication Systems

Special features:

- Very high surge ratings
- Equipped with screw or quick connect (spring loaded) or RJ 45 terminals
- Wall mounting or DIN rail mounting versions available
- High frequency range (up to 250MHz) suitable for all DSL lines

RayTel 10
 RayTel 20
 RayDat SPH-2-230
 RayDat SPH-4-230
 RayDat SLH-2-110
 RayDat SLH-4-110
 RayDat SUI-4-110
 RayDat SRH-2-110
 RayDat SGH-3-110



Symbol Legend:



DIN Rail Mounting



Screw Connect Terminals



Quick Connect Terminals



Plug-In Connection



Modular Design



Shield Directly Grounded

These SPDs protect a subscriber's telecommunication equipment from overvoltages, caused by lightning strikes, switching operations, and surges coming from the telecommunication networks. The complete surge protection on the telecommunication side fully enables signal transmission of the DSL technologies, even in systems with extreme cable runs.

Operational deterioration and insertion loss are negligible in the operating frequency range. The protective module is adapted to the frequency characteristic of the subscriber's twisted pairs since the same module can be used in ADSL, ADSL2 and ADSL2+ protocols over POTS and ISDN lines.

SPD for Telecommunication Side

RayTel 10

C1 • C2 • C3



IEC/EN Category: C1/C2/C3
 Surge Discharge Ratings: I_{n1} : 5 kA, I_{max} : 10 kA
 Voltages: 175 V DC
 Max. Operating Voltage: 175 V DC
 Housing: Compact Design
 Compliance: IEC/EN 61643-21



Technical Data

RayTel 10

Electrical

Maximum Continuous Operating DC Voltage	U_c	175 V
Maximum Operating Current	I_L	150 mA
Nominal Discharge Current (8/20 μ s)	(a/b-PE, a-b) I_n	2.5 kA
Maximum Discharge Current (8/20 μ s)	I_{max}	5 kA
Protection Level at [U_p] at [I_n] (8/20 μ s)	(a-b) U_p	≤ 300 V
Protection Level at [U_p] at [I_n] (8/20 μ s)	(a/b-PE) U_p	≤ 1000 V
Series Resistance at 20°C [R]	R	0.2 - 0.4 Ω
Series Inductance [L]	L	2 x 25 μ H
Capacitance [C]	C	<100 pF
Frequency Range	f_G	up to 10 MHz
Response Time (a-b)	t_A	<5 ns
Response Time (a, b-PE)	t_A	<100 ns
Connection (Input/Output)		RJ11 or RJ45

Mechanical

Temperature Range	-40 °F to +140 °F [-40 °C to +60 °C]
Degree of Protection IEC/EN 60529	IP20 (built-in)
Housing Material	Thermoplastic; Grey; Extinguishing Degree V-0

Order Information

Order Code	
RayTel 10	124 150

RayTel 10

Internal Configuration

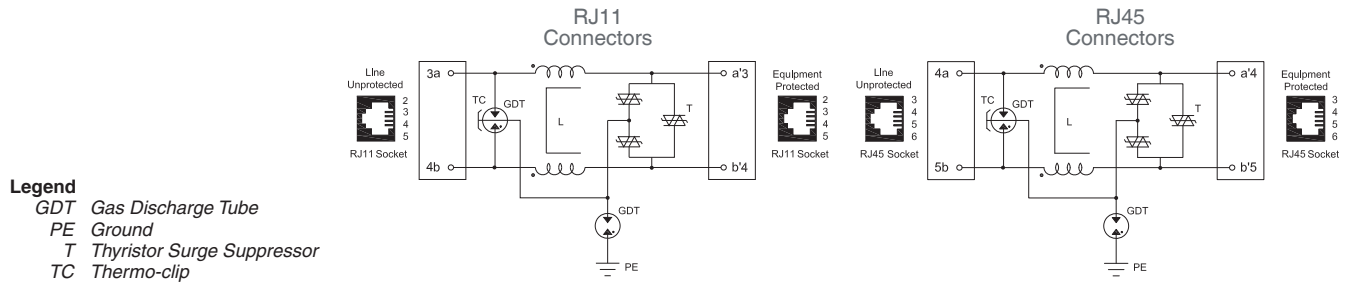

Dimensions & Packaging

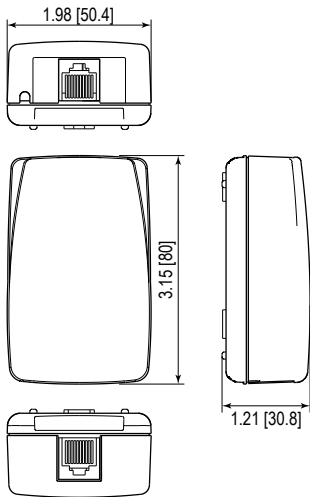

RayTel 10

Dimensions

Weight per Unit	2.46 oz [70g]
Packaging Dimensions (Single Unit)	4.2 × 2.9 × 1.4" [108 × 75 × 36 mm]
Minimum Package Quantity	8 pieces

inches
[mm]

SPD for DSL Networks RayTel 20



IEC/EN Category: D1/C1/C2/C3
 Surge Discharge Ratings: I_n : up to 20kA, I_{imp} : up to 7.5kA
 Voltages: 110V DC
 Max. Operating Voltage: 180V DC
 Frequency Range: up to 250MHz
 Housing: Compact Design
 Compliance: IEC/EN 61643-21



Technical Data

RayTel 20

Electrical

Type per IEC/EN 61643-21		D1/C1/C2/C3
Number of Protected Pairs		1 Pair (2 Conductors)
Nominal Operating Voltage (DC)	U_n	110V
Maximum Continuous Operating Voltage (DC)	U_c	180V
Maximum Continuous Operating Voltage (AC)	U_c	127V
Nominal Current at 40°C	I_L	0.6A
C2 Total Nominal Discharge Current (8/20 μs)	I_n	20kA
C2 Nominal Discharge Current per Line (8/20 μs)	I_n	10kA
D1 Total Lightning Impulse Current (10/350 μs)	I_{imp}	7.5kA
D1 Lightning Impulse Current per Line (10/350 μs)	I_{imp}	2.5kA
Voltage Protection Level at at 1 kV/μs C3	(Line-Line) U_p	<250V
	(Lines-Ground)	<550V
Voltage Protection Level at I_n	(Lines-Ground) U_p	<750V
Series Resistance per Line	R_s	1.6-2.0Ω
Bandwidth	f_G	up to 250 MHz
Capacitance	(Line-Line) C	≤ 20 pF
	(Lines-Ground) C	≤ 10 pF

Mechanical

Temperature Range	-13 °F to +176 °F [-25 °C to +80 °C]
Cross-sectional Area of the Signal Lines	0.13-2.5mm ² (solid)
Cross-sectional Area of the Signal Lines	0.13-2.5mm ² (flexible)
Cross-sectional Area of the Earth Terminal	0.2-2.5 mm ²
Connection Type	PCB Terminals
Degree of Protection IEC/EN 60529	IP 66
Housing Material	Polypropylene; Grey

Order Information

Order Code	
RayTel 20	124 152

RayTel 20

Internal Configuration

Legend

- DB Diode Block
- GDT Gas Discharge Tube
- PG Protective Grounding
- Z Impedance

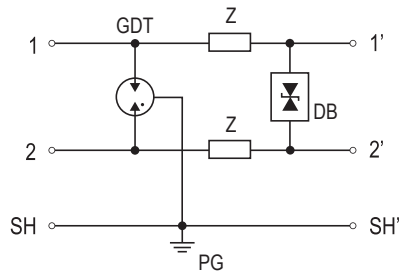

Dimensions & Packaging

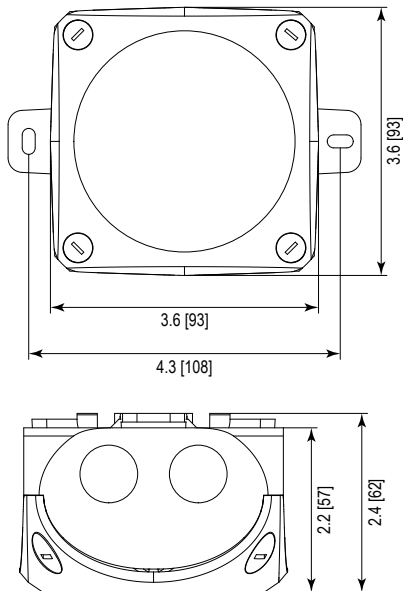

RayTel 20

Dimensions

Weight per Unit	5.29 oz [150 g]
Packaging Dimensions (Single Unit)	3.6 x 3.6 x 2.4" [93 x 93 x 63 mm]
Minimum Package Quantity	1 piece

inches
[mm]

Modular SPD for Single Pair

RayDat SPH-2-230

D1 • C1 • C2 • C3



IEC/EN Category: D1/C1/C2/C3
 Surge Discharge Ratings: I_n : 10 kA, I_{max} : 20 kA, I_{imp} : 2.5 kA
 Voltages: 230V DC
 Frequency Range: 30 MHz, 10 MHz
 Compliance: IEC/EN 61643-21
 Configuration:

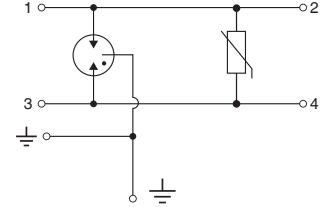

Technical Data

SPH-2-xxx

230

Electrical

Lines Protected		1 (2 Conductors)
Nominal Operating Voltage (DC)	U_n	230V
Maximum Continuous Operating Voltage (DC)	U_c	320V
Rated Load Current at 25°C	I_L	5 A
C2 Nominal Discharge Current (8/20 μs)	I_n	10 kA
Maximum Discharge Current (8/20 μs)	I_{max}	20 kA
D1 Impulse Current (10/350 μs)	I_{imp}	2.5 kA
Residual Voltage at 5 kA (8/20 μs)	(Line-Line) U_{res}	< 700V
Rated Spark Overvoltage	(Line-Ground)	350-550V
	(Line-Line)	350-429V
Response Time Overvoltage Protection	(Line-Line) t_A	< 25 ns
	(Line-Ground)	< 100 ns
Insulation Resistance of the Protection	(Line-Ground) R_{iso}	> 1 GΩ/100 V
	(Line-Line)	≥ 100 MΩ
Serial Resistance per Path	R	0.1 Ω
Transverse Capacitance	(Line-Line) C	100 pF
	(Line-Ground)	5 pF
Cut-off Frequency	f_G	10 MHz

Mechanical

Temperature Range	-40 °F to +176 °F [-40 °C to +80 °C]
Terminal Cross Section Multi-strand (max.)	12 AWG
	4 mm ² , 2.5 mm ² Q Version
Terminal Screw Torque	4.5 lbf-in [0.5 Nm]
Degree of Protection IEC/EN 60529	IP 20 (built-in)
Housing Material	Thermoplastic; Grey; Extinguishing Degree V-0
Mounting IEC/EN 60715	35mm DIN Rail

Order Information

Order Code	230
SPH-2-xxx	7081.06
SPH-2-xxxQ (Quick Connect Terminals)	7085.26
SPH-2-xxxM (module)	7081.08

RayDat SPH-2-230

Internal Configuration

Legend

- GDT Gas Discharge Tube
- MOV Metal Oxide Varistor
- PG Protective Grounding

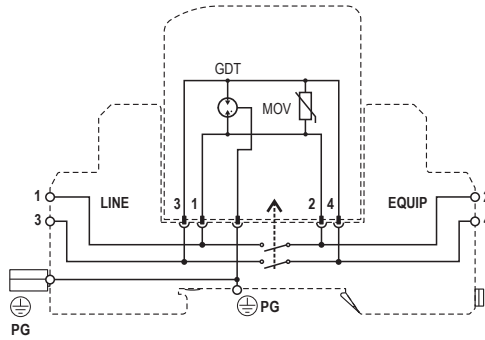

Dimensions & Packaging

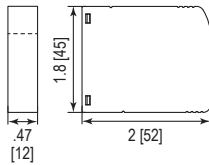
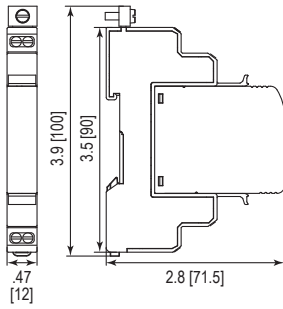

SPH-2-xxx	230
Dimensions	
Weight per Unit	2.11 oz [60g]
Dimensions DIN 43880	2/3 TE
Packaging Dimensions (Single Unit)	3.4 x .59 x 4" [87 x 15 x 102 mm]
Minimum Package Quantity	15 pieces

SPH-2-xxxM Series	230
Dimensions	
Weight per Unit	.91 oz [26g]
Packaging Dimensions (Single Unit)	3.4 x .59 x 4" [87 x 15 x 102 mm]
Minimum Package Quantity	15 pieces

Quick Connect Terminals

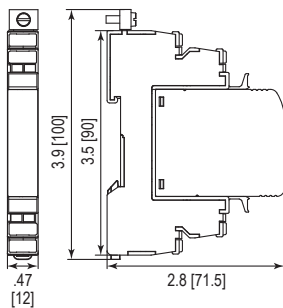

SPH-2-xxxQ Series	230
Dimensions	
Weight per Unit	2.18 oz [62g]
Dimensions DIN 43880	2/3 TE
Packaging Dimensions (Single Unit)	3.4 x .59 x 4" [87 x 15 x 102 mm]
Minimum Package Quantity	15 pieces

inches
[mm]



Modular SPD for Single Pair

RayDat SLH-2-110

D1 • C1 • C2 • C3



IEC/EN Category: D1/C1/C2/C3
 Surge Discharge Ratings: I_n : 10 kA, I_{max} : 20 kA, I_{imp} : 2.5 kA
 Voltages: 110V DC
 Frequency Range: 30 MHz
 Housing: Modular Design
 Compliance: IEC/EN 61643-21
 Configuration:

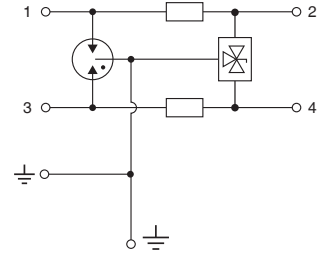

Technical Data

SLH-2-xxx

110

Electrical

Lines Protected		1 (2 Conductors)
Nominal Operating Voltage (DC)	U_n	110V
Maximum Continuous Operating Voltage (DC)	U_c	170V
Rated Load Current at 25°C	I_L	1 A
C2 Nominal Discharge Current (8/20 μ s)	I_n	10 kA
Maximum Discharge Current (8/20 μ s)	I_{max}	20 kA
D1 Impulse Current (10/350 μ s)	I_{imp}	2.5 kA
Residual Voltage at 5 kA (8/20 μ s)	U_{res}	< 450V
Rated Spark Overvoltage	(Line-Ground)	184-264V
	(Line-Line)	184-264V
Response Time Overvoltage Protection	t_A	< 1 ns
Thermal Protection		Yes
Insulation Resistance of the Protection	R_{iso}	$\geq 170 M\Omega$
Serial Resistance per Path	R	1.6-2.0 Ω
Transverse Capacitance	C	50 pF
Cut-off Frequency	f_G	30 MHz

Mechanical

Temperature Range		-40 °F to +176 °F [-40 °C to +80 °C]
Terminal Cross Section Multi-strand (max.)		12 AWG [4 mm ² , 2.5 mm ² Q Version]
Terminal Screw Torque		4.5 lbf-in [0.5 Nm]
Degree of Protection IEC/EN 60529		IP 20 (built-in)
Housing Material		Thermoplastic; Grey; Extinguishing Degree V-0
Mounting IEC/EN 60715		35 mm DIN Rail

Order Information

Order Code		110
SLH-2-xxx		7086.39
SLH-2-xxxQ (Quick Connect Terminals)		7085.12
SLH-2-xxxM (module)		7086.46

RayDat SLH-2-110

Internal Configuration

Legend

- DB Diode Block
- GDT Gas Discharge Tube
- PG Protective Grounding
- R Resistor
- TC Thermo-clip

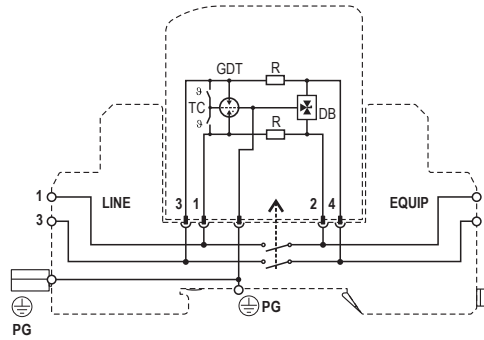

Dimensions & Packaging

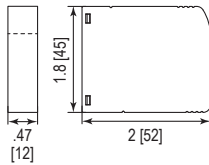
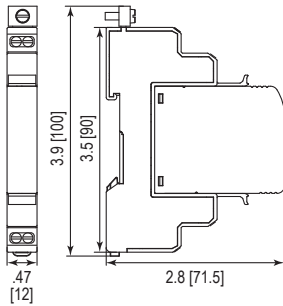

SLH-2-xxx	110
Dimensions	
Weight per Unit	1.83 oz [52 g]
Dimensions DIN 43880	2/3 TE
Packaging Dimensions (Single Unit)	3.4 x .59 x 4" [87 x 15 x 102 mm]
Minimum Package Quantity	15 pieces

SLH-2-xxxM Series	110
Dimensions	
Weight per Unit	.84 oz [24 g]
Packaging Dimensions (Single Unit)	3.4 x .59 x 4" [87 x 15 x 102 mm]
Minimum Package Quantity	15 pieces

Quick Connect Terminals

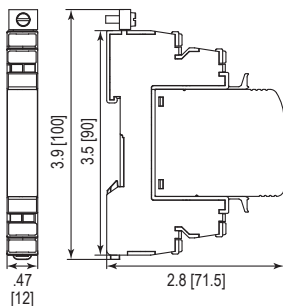

SLH-2-xxxQ Series	110
Dimensions	
Weight per Unit	1.90 oz [54 g]
Dimensions DIN 43880	2/3 TE
Packaging Dimensions (Single Unit)	3.4 x .59 x 4" [87 x 15 x 102 mm]
Minimum Package Quantity	15 pieces

inches
[mm]



Modular SPD for Two Pair

RayDat SLH-4-110

D1 • C1 • C2 • C3



IEC/EN Category: D1/C1/C2/C3
 Surge Discharge Ratings: I_n : 10 kA, I_{max} : 20 kA, I_{imp} : 5 kA
 Voltages: 110V DC
 Frequency Range: 30 MHz
 Housing: Modular Design
 Compliance: IEC/EN 61643-21
 Configuration:

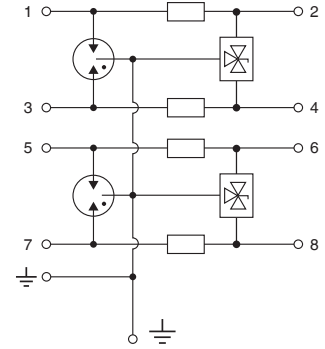

Technical Data

SLH-4-xxx

110

Electrical

Lines Protected		2 (4 Conductors)
Nominal Operating Voltage (DC)	U_n	110V
Maximum Continuous Operating Voltage (DC)	U_c	170V
Rated Load Current at 25°C	I_L	1 A
C2 Nominal Discharge Current (8/20 μ s)	I_n	10 kA
Maximum Discharge Current (8/20 μ s)	I_{max}	20 kA
D1 Impulse Current (10/350 μ s)	I_{imp}	5 kA
Residual Voltage at 5 kA (8/20 μ s)	U_{res}	< 450V
Rated Spark Overvoltage	(Line-Ground)	184-264V
	(Line-Line)	184-264V
Response Time Overvoltage Protection	t_A	< 1 ns
Thermal Protection		Yes
Insulation Resistance of the Protection	R_{iso}	$\geq 170 M\Omega$
Serial Resistance per Path	R	1.6-2.0 Ω
Transverse Capacitance	C	50 pF
Cut-off Frequency	f_G	30 MHz

Mechanical

Temperature Range		-40 °F to +176 °F [-40 °C to +80 °C]
Terminal Cross Section Multi-strand (max.)		12 AWG [4 mm ² , 2.5 mm ² Q Version]
Terminal Screw Torque		4.5 lbf-in [0.5 Nm]
Degree of Protection IEC/EN 60529		IP20 (built-in)
Housing Material		Thermoplastic; Grey; Extinguishing Degree V-0
Mounting IEC/EN 60715		35 mm DIN Rail

Order Information

Order Code		110
SLH-4-xxx		7086.53
SLH-4-xxxQ (Quick Connect Terminals)		7085.20
SLH-4-xxxM (module)		7086.60

RayDat SLH-4-110

Internal Configuration

Legend

- DB Diode Block
- GDT Gas Discharge Tube
- PG Protective Grounding
- R Resistor
- TC Thermo-clip

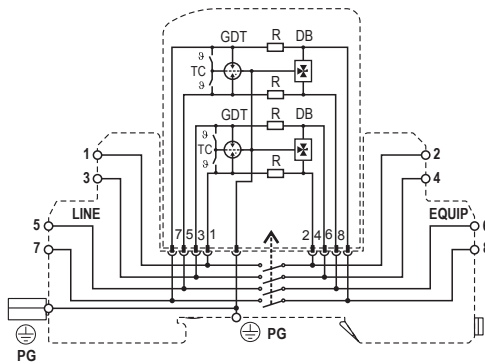

Dimensions & Packaging

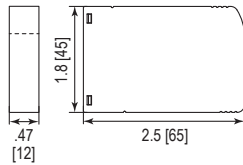
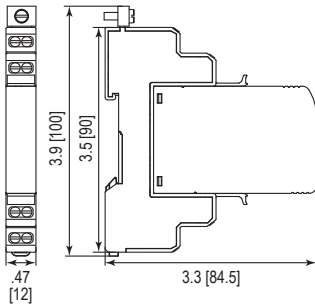

SLH-4-xxx

110

Dimensions

Weight per Unit	2.32 oz [66 g]
Dimensions DIN 43880	2/3 TE
Packaging Dimensions (Single Unit)	3.4 x .59 x 4" [87 x 15 x 102 mm]
Minimum Package Quantity	15 pieces

SLH-4-xxxM Series

110

Dimensions

Weight per Unit	1.05 oz [30 g]
Packaging Dimensions (Single Unit)	3.4 x .59 x 4" [87 x 15 x 102 mm]
Minimum Package Quantity	15 pieces

Quick Connect Terminals

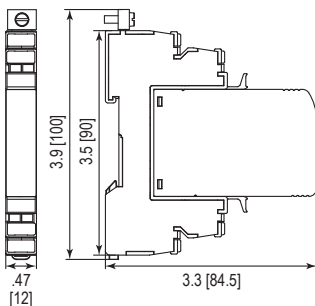

SLH-4-xxxQ Series

110

Dimensions

Weight per Unit	2.32 oz [66 g]
Dimensions DIN 43880	2/3 TE
Packaging Dimensions (Single Unit)	3.4 x .59 x 4" [87 x 15 x 102 mm]
Minimum Package Quantity	15 pieces

inches
[mm]

SPD for Two Pair Exposed Lines

RayDat SUI-4-110

D1 • C1 • C2 • C3



IEC/EN Category: D1/C1/C2/C3
 Surge Discharge Ratings: I_n : 20 kA, I_{max} : 30 kA, I_{imp} : 5 kA
 Voltages: 110V DC
 Frequency Range: 30 MHz
 Housing: Modular Design
 Compliance: IEC/EN 61643-21
 Configuration:

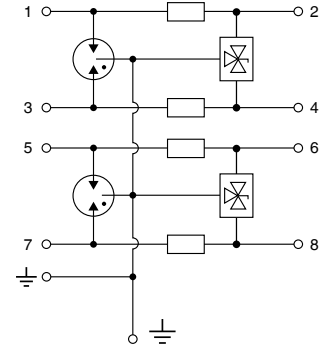

Technical Data

SUI-4-xxx

110

Electrical

Lines Protected		2 (4 Conductors)
Nominal Operating Voltage (DC)	U_n	110V
Maximum Continuous Operating Voltage (DC)	U_c	170V
Rated Load Current at 25°C	I_L	1 A
C2 Nominal Discharge Current (8/20 μ s)	I_n	20 kA
Maximum Discharge Current (8/20 μ s)	I_{max}	30 kA
D1 Impulse Current (10/350 μ s)	I_{imp}	5 kA
Residual Voltage at 5 kA (8/20 μ s)	U_{res}	< 450V
Rated Spark Overvoltage	(Line-Ground)	184-264V
	(Line-Line)	184-264V
Response Time Overvoltage Protection	t_A	< 1 ns
Thermal Protection		Yes
Insulation Resistance of the Protection	R_{iso}	$\geq 170 M\Omega$
Serial Resistance per Path	R	1.6-2.0 Ω
Transverse Capacitance	C	50 pF
Cut-off Frequency	f_G	30 MHz

Mechanical

Temperature Range		-40 °F to +176 °F [-40 °C to +80 °C]
Terminal Cross Section Multi-strand (max.)		12 AWG [4 mm ²]
Terminal Screw Torque		4.5 lbf-in [0.5 Nm]
Degree of Protection IEC/EN 60529		IP20 (built-in)
Housing Material		Thermoplastic; Grey; Extinguishing Degree V-0
Mounting IEC/EN 60715		35 mm DIN Rail

Order Information

Order Code		110
SUI-4-xxx		7083.28
SUI-4-xxxM (module)		7083.36

RayDat SUI-4-110

Internal Configuration

Legend

- DB Diode Block
- GDT Gas Discharge Tube
- PG Protective Grounding
- R Resistor
- TC Thermo-clip

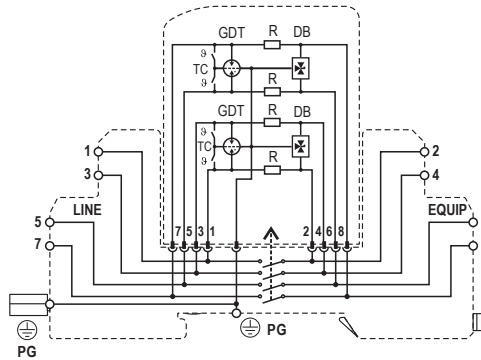

Dimensions & Packaging

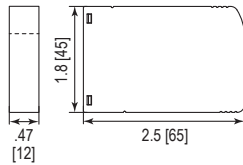
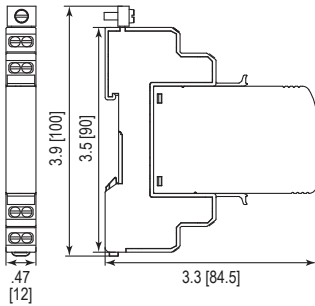

SUI-4-xxx

110

Dimensions

Weight per Unit	2.46 oz [70 g]
Dimensions DIN 43880	2/3 TE
Packaging Dimensions (Single Unit)	3.4 x .59 x 4" [87 x 15 x 102 mm]
Minimum Package Quantity	15 pieces

SUI-4-xxxM Series

110

Dimensions

Weight per Unit	1.05 oz [30 g]
Packaging Dimensions (Single Unit)	3.4 x .59 x 4" [87 x 15 x 102 mm]
Minimum Package Quantity	15 pieces

inches
[mm]

SPD with Remote Contacts

RayDat SRH-2-110

D1 • C1 • C2 • C3



IEC/EN Category: D1/C1/C2/C3
 Surge Discharge Ratings: I_n : 10 kA, I_{max} : 20 kA, I_{imp} : 2.5 kA
 Voltages: 110V DC
 Frequency Range: 30 MHz
 Housing: Modular Design
 Compliance: IEC/EN 61643-21
 Configuration:

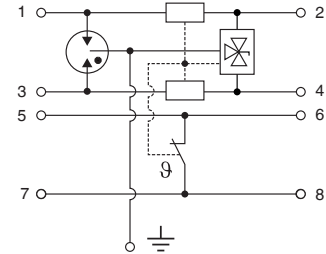

Technical Data

SRH-2-xxx

110

Electrical

Lines Protected		1 (2 Conductors)
Nominal Operating Voltage (DC)	U_n	110V
Maximum Continuous Operating Voltage (DC)	U_c	170V
Rated Load Current at 25°C	I_L	1 A
C2 Nominal Discharge Current (8/20 μ s)	I_n	10 kA
Maximum Discharge Current (8/20 μ s)	I_{max}	20 kA
D1 Impulse Current (10/350 μ s)	I_{imp}	2.5 kA
Residual Voltage at 5 kA (8/20 μ s)	U_{res}	< 450V
Rated Spark Overvoltage	(Line-Ground)	184-264V
	(Line-Line)	184-264V
Response Time Overvoltage Protection	t_A	< 1 ns
Thermal Protection		Yes
Insulation Resistance of the Protection	R_{iso}	$\geq 170 M\Omega$
Serial Resistance per Path	R	1.6-2.0 Ω
Transverse Capacitance	C	50 pF
Cut-off Frequency	f_G	30 MHz

Mechanical

Temperature Range		-40 °F to +176 °F [-40 °C to +80 °C]
Terminal Cross Section Multi-strand (max.)		12 AWG [4 mm ² , 2.5 mm ² Q Version]
Terminal Screw Torque		4.5 lbf-in [0.5 Nm]
Degree of Protection IEC/EN 60529		IP20 (built-in)
Housing Material		Thermoplastic; Grey; Extinguishing Degree V-0
Mounting IEC/EN 60715		35 mm DIN Rail
Remote Contacts Ratings		AC 250V/0.5 A, DC 50V/1 A

Order Information

Order Code		110
SRH-2-xxx		7086.24
SRH-2-xxxQ (Quick Connect Terminals)		7085.40
SRH-2-xxxM (module)		7086.32

RayDat SRH-2-110

Internal Configuration

Legend

- DB Diode Block
- GDT Gas Discharge Tube
- PG Protective Grounding
- R Resistor
- RC Remote Control (NC)
- TC Thermo-clip

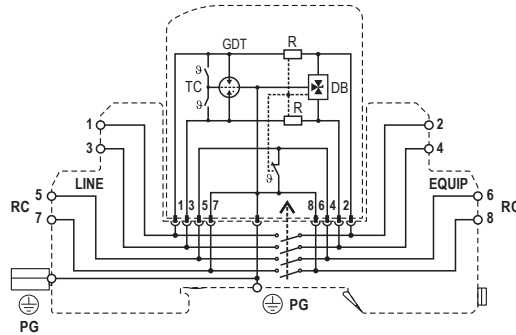

Dimensions & Packaging

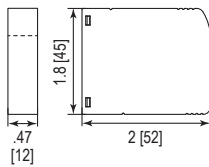
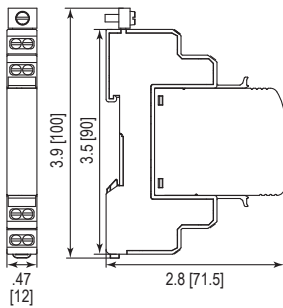

SRH-2-xxx

110

Dimensions

Weight per Unit	2.04 oz [58 g]
Dimensions DIN 43880	2/3 TE
Packaging Dimensions (Single Unit)	3.4 x .59 x 4" [87 x 15 x 102 mm]
Minimum Package Quantity	15 pieces

SRH-2-xxxM Series

110

Dimensions

Weight per Unit	.84 oz [24 g]
Packaging Dimensions (Single Unit)	3.4 x .59 x 4" [87 x 15 x 102 mm]
Minimum Package Quantity	15 pieces

Quick Connect Terminals

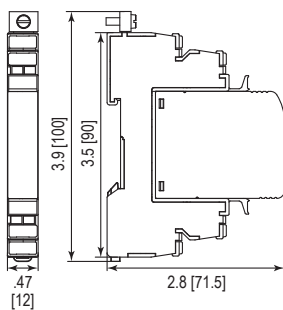

SRH-2-xxxQ Series

110

Dimensions

Weight per Unit	2.11 oz [60 g]
Dimensions DIN 43880	2/3 TE
Packaging Dimensions (Single Unit)	3.4 x .59 x 4" [87 x 15 x 102 mm]
Minimum Package Quantity	15 pieces

inches
[mm]

SPD with Separated Signal Ground (RS 232)

RayDat SGH-3-110

D1 • C1 • C2 • C3



IEC/EN Category: D1/C1/C2/C3
 Surge Discharge Ratings: I_n : 10 kA, I_{max} : 20 kA, I_{imp} : 2.5 kA
 Voltages: 110V DC
 Frequency Range: 30 MHz
 Housing: Modular Design
 Compliance: IEC/EN 61643-21
 Configuration:

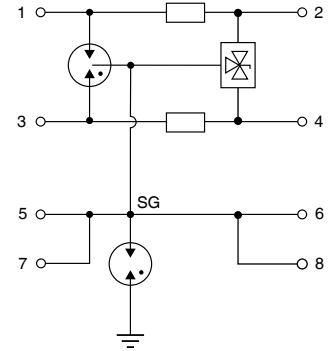

Technical Data

SGH-3-xxx

Electrical

Lines Protected		1 (2 Conductors)
Nominal Operating Voltage (DC)	U_n	110V
Maximum Continuous Operating Voltage (DC)	U_c	170V
Rated Load Current at 25°C	I_L	1 A
C2 Nominal Discharge Current (8/20 μs)	I_n	10 kA
Maximum Discharge Current (8/20 μs)	I_{max}	20 kA
D1 Impulse Current (10/350 μs)	I_{imp}	2.5 kA
Residual Voltage at 5 kA (8/20 μs)	(Line-Line) U_{res}	< 450V
Rated Spark Overvoltage	(SG-Ground)	184-276V
	(Line-Line), (Line-SG)	184-264V
Response Time Overvoltage Protection	(Line-Line) t_A	< 1 ns
	(Line-Ground)	< 100 ns
Insulation Resistance of the Protection	(Line-Line) R_{iso}	≥ 170 MΩ
	(Line-Ground)	> 1 GΩ/100V
Serial Resistance per Path	R	1.6-2.0 Ω
Transverse Capacitance	(Line-Line) C	50 pF
	(Line-Ground)	5 pF
Cut-off Frequency	f_G	30 MHz

Mechanical

Temperature Range	-40 °F to +176 °F [-40 °C to +80 °C]
Terminal Cross Section Multi-strand (max.)	12 AWG [4 mm ² , 2.5 mm ² Q Version]
Terminal Screw Torque	4.5 lbf-in [0.5 Nm]
Degree of Protection IEC/EN 60529	IP 20 (built-in)
Housing Material	Thermoplastic; Grey; Extinguishing Degree V-0
Mounting IEC/EN 60715	35mm DIN Rail

Order Information

Order Code	110
SGH-3-xxx	7086.68
SGH-3-xxxM (module)	7086.76

RayDat SGH-3-110

Internal Configuration

Legend

- DB Diode Block
- GDT Gas Discharge Tube
- R Resistor
- PG Protective Grounding
- SG Signal Grounding
- TC Thermo-clip

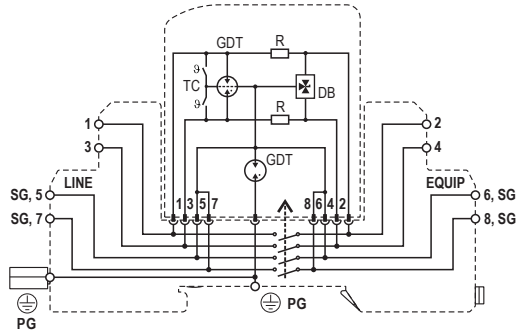

Dimensions & Packaging

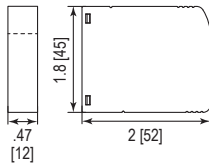
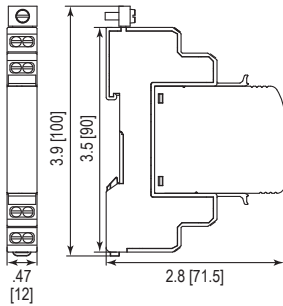

SGH-3-xxx

110

Dimensions

Weight per Unit	2.11 oz [60g]
Dimensions DIN 43880	2/3 TE
Packaging Dimensions (Single Unit)	3.4 x .59 x 4" [87 x 15 x 102 mm]
Minimum Package Quantity	15 pieces

SGH-3-xxxM Series

110

Dimensions

Weight per Unit	.91 oz [26g]
Packaging Dimensions (Single Unit)	3.4 x .59 x 4" [87 x 15 x 102 mm]
Minimum Package Quantity	15 pieces

inches
[mm]



Surge Protective Devices (SPDs)
for Coaxial & RF Systems



Coaxial & RF Systems

Special features:

- Very high surge ratings
- Equipped with various types of terminals
- High frequency range (up to 250MHz) suitable for all DSL lines
- Robust metal housing

- RayCox BNC
- RayCox IEC, F
- RayDat CP BNC
- RayDat CP 7/16
- RayDat CP N
- RayDat CP N-6G
- RayDat CP TNC-6G
- RayDat CP UHF
- RayDat CP F75
- RayDat CP TV75
- RayDat CP SMA-MF

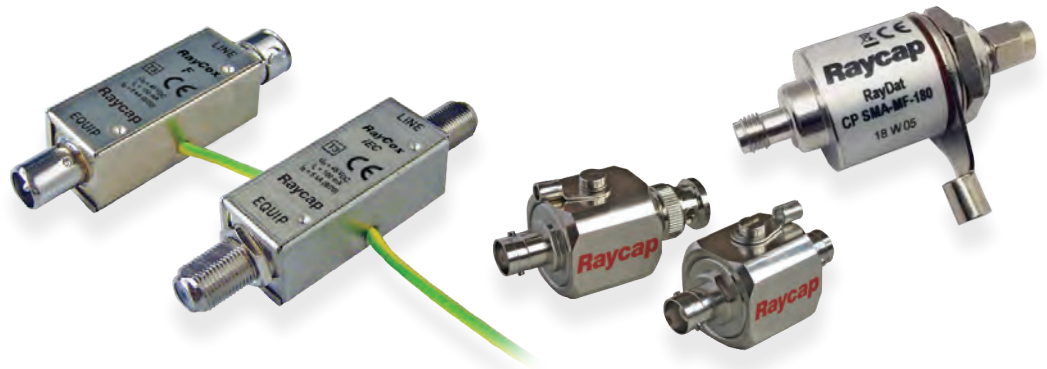

Symbol Legend:

- Compact Design
- Quick Connect Terminals
- Plug-In Connection
- Shield Directly Grounded

Coaxial protection devices are intended to protect TV sets, aerial amplifiers, CCTV/ CATV systems as well as RF antenna systems. Moreover, they are suitable for frequencies up to 6 GHz.

The careful design, low capacitance gas discharge arresters and high-quality termination connectors ensure a minimum of insertion loss throughout the frequency band.

Surge protection devices are designed to match the requirements for 50 Ohm or 75 Ohm typical impedance. Different types of connectors (BNC, IEC TV, BNC, 7/16, N, TNC UHF and SMA) are used to enable easy installation.

The CP coaxial cable protectors are designed in accordance with IEC 61643-21: 2012 standards and regulations.



Coaxial SPD for Analog Video Surveillance Systems

RayCox BNC Series

C1 • C2 • C3



IEC/EN Category: C1/C2/C3
 Surge Discharge Ratings: I_n : 10 kA, I_{max} : 20 kA
 Voltages: 10, 24 VDC
 Max. Operating Voltage: 12, 24 VDC
 Frequency Range: 100 MHz
 Series Load Current: 100 mA
 Enclosure: In-line Installation
 Termination: BNC Connectors
 Housing: Shielded Enclosure
 Compliance: IEC/EN 61643-21



Technical Data

BNC		BNC 5	BNC 12
Electrical			
Nominal Operating Voltage (DC)	U_n	10V	24V
Maximum Continuous Operating Voltage (DC)	U_c	12V	28V
Rated Operating Current at 25°C	I_L		100 mA
C2 Nominal Discharge Current (8/20µs)	I_n		10 kA
Maximum Discharge Current (8/20µs)	I_{max}		20 kA
Residual Voltage at 5 kA (8/20µs)	(Wire-Shield) U_{res}	< 35V	< 65V
Rated Spark Overvoltage	(Wire-Shield)	13.5V – 16.5V	30V – 36V
	(Shield-Ground)	72V – 108V	72V – 108V
Response Time Overvoltage Protection	(Wire-Shield) t_A		< 10 ns
	(Shield-Ground)		< 100 ns
Insulation Resistance of Protection	(Wire-Shield) R_{iso}	≥ 12 MΩ	≥ 28 MΩ
	(Shield-Ground)		≥ 1 GΩ
Serial Resistance per Path	R		9 – 11 Ω
Transverse Capacitance	(Wire-Shield) C		30 pF
	(Shield-Ground)		1 pF
Cut-off Frequency	f_G		100 MHz
Transmission Rate			16 Mbit/s
Mechanical			
Temperature Range		-40 °F to +176 °F [-40 °C to +80 °C]	
Connection		BNC Connector	
Degree of Protection IEC/EN 60529		IP 20 (built-in)	
Housing Material		Metal	
Order Information			
Order Code		BNC 5	BNC 12
BNC xx		7050.22	7050.13

RayCox BNC Series

Internal Configuration

Legend

- BD Bi-directional TVS Diode
- C Capacitor
- GDT Gas Discharge Tube
- PG Protective Grounding
- R Resistor

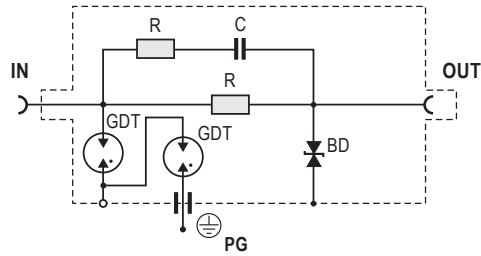

Dimensions & Packaging

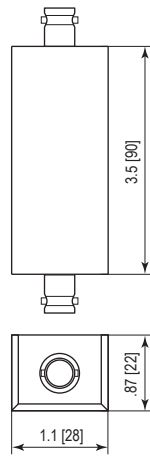

BNC	BNC 5	BNC 12
Dimensions		
Weight per Unit	2.04 oz [58g]	
Packaging Dimensions (Single Unit)	5.5 x 7.9" [140 x 200 mm]	

inches
[mm]

Coaxial SPD for TV & Cable TV
RayCox IEC 48, F 48
C1 • C2 • C3

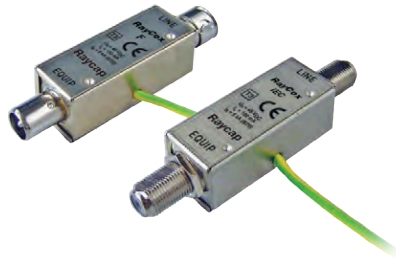

IEC/EN Category: C1/C2/C3
 Surge Discharge Ratings: I_n : 5 kA
 Voltages: 48 VDC
 Max. Operating Voltage: 60 VDC
 Frequency Range: 40–860 MHz
 Series Load Current: 100 mA
 Termination: IEC TV or F Connectors
 Housing: In-line Installation, Shielded Enclosure
 Compliance: IEC/EN 61643-21



Technical Data

	IEC 48	F 48
Electrical		
Nominal Operating Voltage (DC)	U_n	48V
Maximum Continuous Operating Voltage (DC)	U_c	60V
Rated Operating Current at 25°C	I_L	100 mA
C2 Nominal Discharge Current (8/20 μs)	I_n	5 kA
Residual Voltage at 5 kA (8/20 μs)	U_{res}	<500V
Rated Spark Overvoltage (Wire-Shield)		90V–110V
Response Time Overvoltage Protection (Wire-Shield)	t_A	<25 ns
Insulation Resistance of Protection (Wire-Shield)	R_{iso}	≥ 6 MΩ
Serial Resistance per Path	R	<0.1 Ω
Frequency Range	f_G	40–860 MHz
Mechanical		
Temperature Range	-40 °F to +176 °F [-40 °C to +80 °C]	
Connection	TV Connector	F Connector
Degree of Protection IEC/EN 60529	IP20 (built-in)	
Housing Material	Metal	
Order Information		
Order Code	IEC 48	F 48
XXX 48	125 093	125 094

RayCox IEC 48, F 48

Internal Configuration

- Legend**
 C Capacitor
 L Inductor
 MOV Metal Oxide Varistor
 PG Protective Grounding

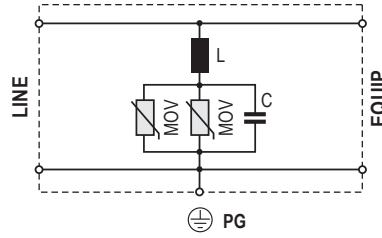

Dimensions & Packaging

IEC 48

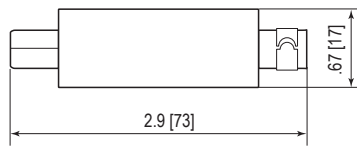

F 48

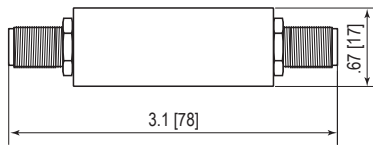

IEC 48 F 48

Dimensions	IEC 48	F 48
Weight per Unit	1.13 oz [32g]	
Packaging Dimensions (Single Unit)	3.5 × 5.9" [90 × 150 mm]	

inches
[mm]



In-line SPD for Coaxial & RF Systems
RayDat CP BNC Series
C1 • C2 • C3



IEC/EN Category: C1/C2/C3
 Surge Discharge Ratings: I_n : 10 kA, I_{max} : 20 kA
 Max. Operating Voltage: 70, 180, 280 V
 Maximum Peak Power: 40, 125, 300 W
 Frequency Range: DC–2.6 GHz
 Impedance: 50 Ω
 Insertion Loss: < 0.4 dB
 Return Loss: > 20 dB
 Termination: BNC Type (F-F, M-F)
 Housing: In-line Installation, Shielded Enclosure
 Compliance: IEC/EN 61643-21



Technical Data

CP BNC		70	180	280
Electrical				
Maximum Continuous Operating Voltage	U_c	70 V	180 V	280 V
Maximum Peak Power	P_{max}	40 W	125 W	300 W
C2 Nominal Discharge Current (8/20 μ s)	I_n		10 kA	
Maximum Discharge Current (8/20 μ s)	I_{max}		20 kA	
Residual Voltage at (1 kV/ μ s)	U_{res}	< 600 V	< 700 V	< 900 V
Impedance	Z		50 Ω	
Insertion Loss	I_L		< 0.4 dB	
Return Loss	R_L		> 20 dB	
Insulation Resistance of Protection	R_{iso}		> 10 G Ω	
Frequency Range	f_G		0–2.6 GHz	
Mechanical				
Temperature Range		-40 °F to +176 °F [-40 °C to +80 °C]		
Connection		BNC Female/Female		BNC Male/Female
Degree of Protection IEC/EN 60529			IP 20 (built-in)	
Housing Material			Metal	
Order Information				
Order Code		70	180	280
CP BNC-FF-xxx		800 850	800 851	800 852
CP BNC-MF-xxx		800 853	800 854	800 855

RayDat CP BNC Series

Internal Configuration

Legend
 GDT Gas Discharge Tube
 PE Ground

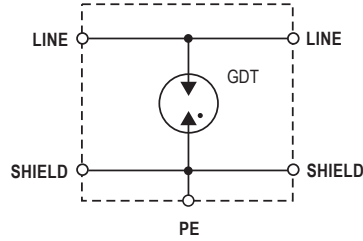

Dimensions & Packaging

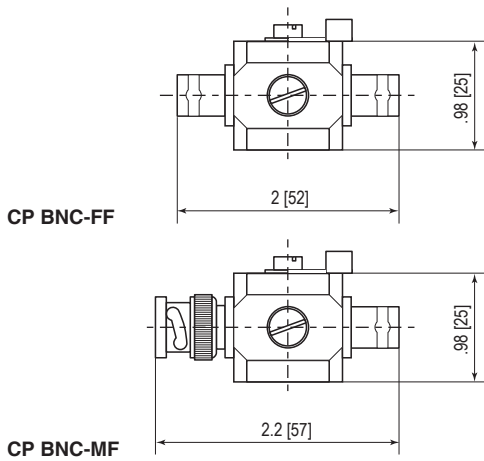

CP BNC	CP BNC-FF-xxx			CP BNC-MF-xxx		
	70	180	280	70	180	280
Dimensions						
Weight per Unit	3.74 oz [106g]			4.02 oz [114g]		
Packaging Dimensions (Single Unit)	2.9 x 1.2 x 1.2" [73 x 30 x 30mm]					
Minimum Package Quantity	100 pieces					

inches
[mm]



In-line SPD for Coaxial & RF Systems
RayDat CP 7/16 Series
C1 • C2 • C3

CCP-7/16 Series



IEC/EN Category: C1/C2/C3
 Surge Discharge Ratings: I_n : 10 kA, I_{max} : 20 kA
 Max. Operating Voltage: 70, 180, 280 V
 Maximum Peak Power: 40, 125, 300 W
 Frequency Range: DC–2.5 GHz
 Impedance: 50 Ω
 Insertion Loss: < 0.2 dB
 Return Loss: > 20 dB
 Termination: 7/16 Type (M-F)
 Housing: Bulkhead Installation,
 Shielded Enclosure
 Compliance: IEC/EN 61643-21



Technical Data

CP 7/16-MF		70	180	280
Electrical				
Maximum Continuous Operating Voltage	U_c	70 V	180 V	280 V
Maximum Peak Power	P_{max}	40 W	125 W	300 W
C2 Nominal Discharge Current (8/20 μ s)	I_n		10 kA	
Maximum Discharge Current (8/20 μ s)	I_{max}		20 kA	
Residual Voltage at (1 kV/ μ s)	U_{res}	< 600 V	< 700 V	< 900 V
Impedance	Z		50 Ω	
Insertion Loss	I_L		< 0.2 dB	
Return Loss	R_L		> 20 dB	
Insulation Resistance of Protection	R_{iso}		> 10 G Ω	
Frequency Range	f_G		0–2.5 GHz	
Mechanical				
Temperature Range		-40 °F to +176 °F [-40 °C to +80 °C]		
Connection		7/16 Male/Female		
Degree of Protection IEC/EN 60529		IP 20 (built-in)		
Housing Material		Metal		
Order Information				
Order Code		70	180	280
CP 7/16-MF-xxx		800 856	800 857	800 858

RayDat CP 7/16 Series

Internal Configuration

Legend

GDT Gas Discharge Tube
PE Ground

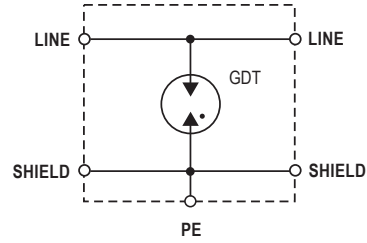

Dimensions & Packaging

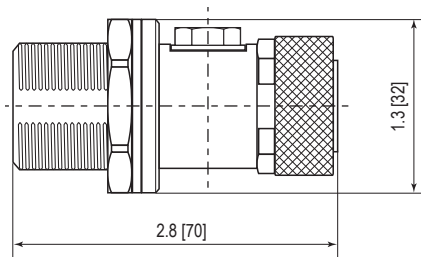

CP 7/16-MF	70	180	280
Dimensions			
Weight per Unit		7.7 oz [218g]	
Packaging Dimensions (Single Unit)		3.2 × 1.6 × 1.6" [82 × 40 × 40mm]	
Minimum Package Quantity		100 pieces	

inches
[mm]

RoHS
COMPLIANT  CE

In-line SPD for Coaxial & RF Systems

RayDat CP N Series

C1 • C2 • C3



IEC/EN Category: C1/C2/C3
 Surge Discharge Ratings: I_n : 10 kA, I_{max} : 20 kA
 Max. Operating Voltage: 70, 180, 280 V
 Maximum Peak Power: 40, 125, 300 W
 Frequency Range: DC–2.6 GHz
 Impedance: 50 Ω
 Insertion Loss: < 0.4 dB
 Return Loss: > 20 dB
 Termination: N Type (F-F, M-F)
 Housing: In-line Installation, Shielded Enclosure
 Compliance: IEC/EN 61643-21



Technical Data

CP-N		70	180	280
Electrical				
Maximum Continuous Operating Voltage	U_c	70 V	180 V	280 V
Maximum Peak Power	P_{max}	40 W	125 W	300 W
C2 Nominal Discharge Current (8/20 μ s)	I_n	10 kA		
Maximum Discharge Current (8/20 μ s)	I_{max}		20 kA	
Residual Voltage at (1 kV/ μ s)	U_{res}	< 600 V	< 700 V	< 900 V
Impedance	Z		50 Ω	
Insertion Loss	I_L		< 0.4 dB	
Return Loss	R_L		> 20 dB	
Insulation Resistance of Protection	R_{iso}		> 10 G Ω	
Frequency Range	f_G		0–2.6 GHz	
Mechanical				
Temperature Range		-40 °F to +176 °F [-40 °C to +80 °C]		
Connection		N Female/Female		N Male/Female
Degree of Protection IEC/EN 60529			IP 20 (built-in)	
Housing Material			Metal	
Order Information				
Order Code		70	180	280
CP N-FF-xxx		800 859	800 860	800 861
CP N-MF-xxx		800 862	800 863	800 864

RayDat CP N Series

Internal Configuration

Legend
 GDT Gas Discharge Tube
 PE Ground

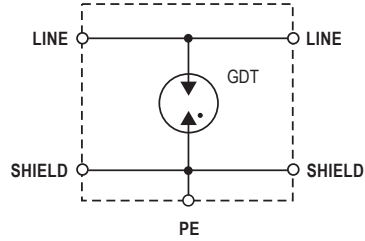

Dimensions & Packaging

CP N-FF

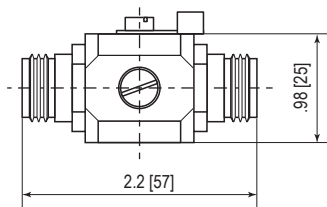

CP N-MF

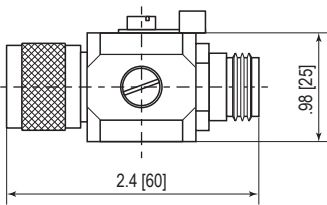

CP N	CP N-FF-xxx			CP N-MF-xxx		
	70	180	280	70	180	280
Dimensions						
Weight per Unit	4.87 oz [138 g]			5.01 oz [142 g]		
Packaging Dimensions (Single Unit)	2.9 x 1.2 x 1.2" [73 x 30 x 30 mm]					
Minimum Package Quantity	100 pieces					

inches
[mm]

RoHS COMPLIANT  CE

In-line SPD for High Frequency Coaxial & RF Systems

RayDat CP N-6G Series

C1 • C2 • C3



IEC/EN Category: C1/C2/C3
 Surge Discharge Ratings: I_n : 10 kA, I_{max} : 20 kA
 Max. Operating Voltage: 180 V
 Maximum Peak Power: 125 W
 Frequency Range: DC–6.0 GHz
 Impedance: 50 Ω
 Insertion Loss: < 0.4 dB
 Return Loss: > 20 dB
 Termination: N Type (F-F, M-F)
 Housing: Bulkhead Installation,
 Shielded Enclosure
 Compliance: IEC/EN 61643-21



Technical Data

CP N-6G	CP N-6G-FF	CP N-6G-MF
Electrical		
Maximum Continuous Operating Voltage	U_c	180 V
Maximum Peak Power	P_{max}	125 W
C2 Nominal Discharge Current (8/20 μ s)	I_n	10 kA
Maximum Discharge Current (8/20 μ s)	I_{max}	20 kA
Residual Voltage at (1 kV/ μ s)	U_{res}	< 700 V
Impedance	Z	50 Ω
Insertion Loss	I_L	< 0.4 dB
Return Loss	R_L	> 20 dB
Insulation Resistance of Protection	R_{iso}	> 10 G Ω
Frequency Range	f_G	0–6.0 GHz
Mechanical		
Temperature Range	-40 °F to +176 °F [-40 °C to +80 °C]	
Connection	N Female/Female	N Male/Female
Degree of Protection IEC/EN 60529	IP 20 (built-in)	
Housing Material	Metal	
Order Information		
Order Code		
CP N-6G-XX	800 865	800 866

RayDat CP N-6G Series

Internal Configuration

Legend

GDT Gas Discharge Tube
PE Ground

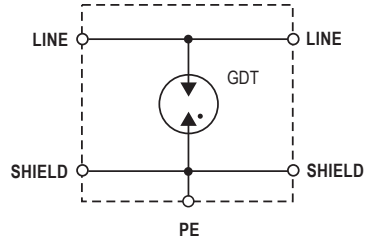

Dimensions & Packaging

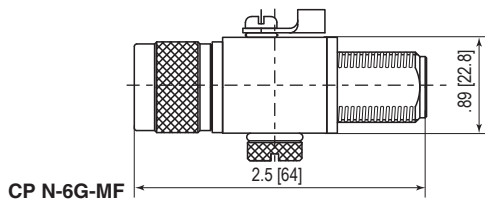
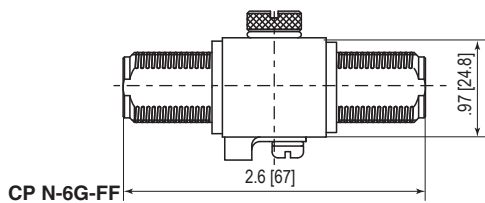

CP N-6G	CP N-6G-FF	CP N-6G-MF
Dimensions		
Weight per Unit	4.65 oz [132 g]	4.58 oz [130 g]
Packaging Dimensions (Single Unit)	2.9 × 1.2 × 1.2" [73 × 30 × 30 mm]	
Minimum Package Quantity	100 pieces	

inches
[mm]

RoHS COMPLIANT  CE

In-line SPD for High Frequency Coaxial & RF Systems

RayDat CP TNC-6G Series

C1 • C2 • C3



IEC/EN Category: C1/C2/C3
 Surge Discharge Ratings: I_n : 10 kA, I_{max} : 20 kA
 Max. Operating Voltage: 180 V
 Maximum Peak Power: 125 W
 Frequency Range: DC–6.0 GHz
 Impedance: 50 Ω
 Insertion Loss: < 0.4 dB
 Return Loss: > 20 dB
 Termination: TNC Type (F-F, M-F)
 Housing: In-line Installation, Shielded Enclosure
 Compliance: IEC/EN 61643-21



Technical Data

CP TNC-6G	CP TNC-6G-FF	CP TNC-6G-MF
Electrical		
Maximum Continuous Operating Voltage	U_c	180 V
Maximum Peak Power	P_{max}	125 W
C2 Nominal Discharge Current (8/20 μ s)	I_n	10 kA
Maximum Discharge Current (8/20 μ s)	I_{max}	20 kA
Residual Voltage at (1 kV/ μ s)	U_{res}	< 700 V
Impedance	Z	50 Ω
Insertion Loss	I_L	< 0.4 dB
Return Loss	R_L	> 20 dB
Insulation Resistance of Protection	R_{iso}	> 10 G Ω
Frequency Range	f_G	0–6.0 GHz
Mechanical		
Temperature Range	-40 °F to +176 °F [-40 °C to +80 °C]	
Connection	TNC Female/Female	TNC Male/Female
Degree of Protection IEC/EN 60529	IP 20 (built-in)	
Housing Material	Metal	
Order Information		
Order Code		
CP TNC-6G-XX	800 867	800 868

RayDat CP TNC-6G Series

Internal Configuration

Legend
 GDT Gas Discharge Tube
 PE Ground

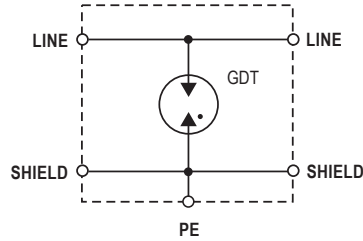

Dimensions & Packaging

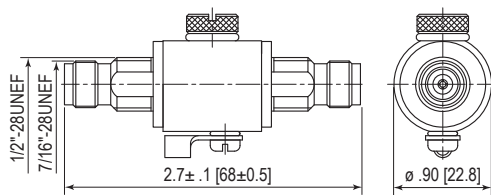

CP TNC-6G-FF

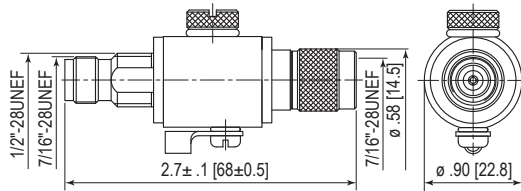

CP TNC-6G-MF

CP TNC-6G	CP TNC-6G-FF	CP TNC-6G-MF
Dimensions		
Weight per Unit	4.6 oz [130g]	4.51 oz [128g]
Packaging Dimensions (Single Unit)	2.9 × 1.2 × 1.2" [73 × 30 × 30mm]	
Minimum Package Quantity	100 pieces	

inches
[mm]

RoHS COMPLIANT  CE

In-line SPD for Coaxial & RF Systems
RayDat CP UHF Series
C1 • C2 • C3



IEC/EN Category: C1/C2/C3
 Surge Discharge Ratings: I_n : 10 kA, I_{max} : 20 kA
 Max. Operating Voltage: 70, 180, 280 V
 Maximum Peak Power: 40, 125, 300 W
 Frequency Range: DC–600 MHz
 Impedance: 50 Ω
 Insertion Loss: < 0.4 dB
 Return Loss: > 20 dB
 Termination: UHF Type (F-F, M-F)
 Housing: In-line Installation, Shielded Enclosure
 Compliance: IEC/EN 61643-21



Technical Data

CP UHF		70	180	280
Electrical				
Maximum Continuous Operating Voltage	U_c	70 V	180 V	280 V
Maximum Peak Power	P_{max}	40 W	125 W	300 W
C2 Nominal Discharge Current (8/20 μ s)	I_n		10 kA	
Maximum Discharge Current (8/20 μ s)	I_{max}		20 kA	
Residual Voltage at (1 kV/ μ s)	U_{res}	< 600 V	< 700 V	< 900 V
Impedance	Z		50 Ω	
Insertion Loss	I_L		< 0.4 dB	
Return Loss	R_L		> 20 dB	
Insulation Resistance of Protection	R_{iso}		> 10 G Ω	
Frequency Range	f_G		0–600 MHz	
Mechanical				
Temperature Range		-40 °F to +176 °F [-40 °C to +80 °C]		
Connection		UHF Female/Female		UHF Male/Female
Degree of Protection IEC/EN 60529		IP 20 (built-in)		
Housing Material		Metal		
Order Information				
Order Code		70	180	280
CP UHF-FF-xxx		800 869	800 870	800 871
CP UHF-MF-xxx		800 872	800 873	800 874

RayDat CP UHF Series

Internal Configuration

Legend

GDT Gas Discharge Tube
PE Ground

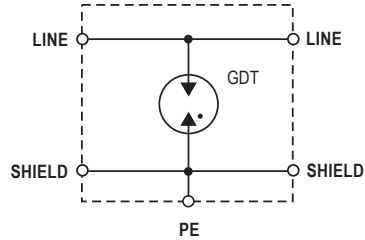

Dimensions & Packaging

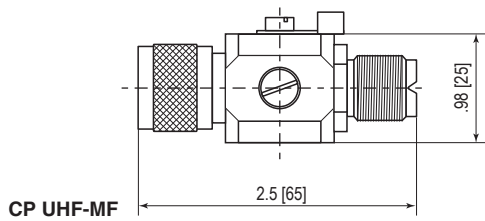
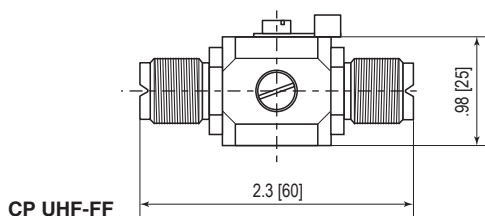

CP UHF	CP UHF-FF-xxx			CP UHF-MF-xxx		
	70	180	280	70	180	280
Dimensions						
Weight per Unit	3.67 oz [104 g]			3.67 oz [104 g]		
Packaging Dimensions (Single Unit)	2.4 x 1.2 x 1.4" [62 x 30 x 35 mm]					
Minimum Package Quantity	100 pieces					

inches
[mm]

In-line SPD for Coaxial & RF Systems

RayDat CP F75 Series

C1 • C2 • C3



IEC/EN Category: C1/C2/C3
 Surge Discharge Ratings: I_n : 10 kA, I_{max} : 20 kA
 Max. Operating Voltage: 70, 180V
 Maximum Peak Power: 40, 125W
 Frequency Range: DC–2.0 GHz
 Impedance: 75 Ω
 Insertion Loss: < 0.4 dB
 Return Loss: > 20 dB
 Termination: F Type (F-F, M-F)
 Housing: In-line Installation, Shielded Enclosure
 Compliance: IEC/EN 61643-21



Technical Data

CP F75	70	180	
Electrical			
Maximum Continuous Operating Voltage	U_c	70V	180V
Maximum Peak Power	P_{max}	40W	125W
C2 Nominal Discharge Current (8/20 μ s)	I_n		10 kA
Maximum Discharge Current (8/20 μ s)	I_{max}		20 kA
Residual Voltage at (1 kV/ μ s)	U_{res}	<600V	<700V
Impedance	Z		75 Ω
Insertion Loss	I_L		<0.4 dB
Return Loss	R_L		>20 dB
Insulation Resistance of Protection	R_{iso}		> 10 G Ω
Frequency Range	f_G		0–2.0 GHz
Mechanical			
Temperature Range		-40 °F to +176 °F [-40 °C to +80 °C]	
Connection		F Female/Female	F Male/Female
Degree of Protection IEC/EN 60529		IP20 (built-in)	
Housing Material		Metal	
Order Information			
Order Code	70	180	
CP F75-FF-xxx	800 875	800 876	
CP F75-MF-xxx	800 877	800 878	

RayDat CP F75 Series

Internal Configuration

Legend
 GDT Gas Discharge Tube
 PE Ground

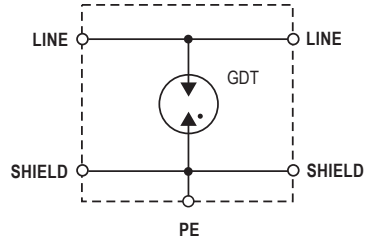

Dimensions & Packaging

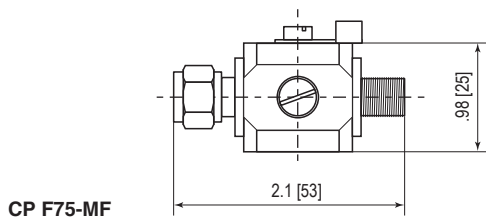
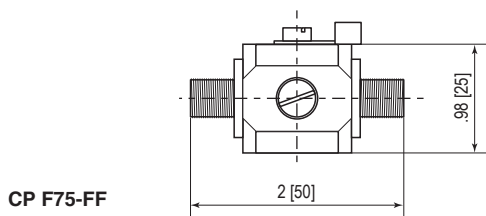

CP F75	CP F75-FF		CP F75-MF	
	70	180	70	180
Dimensions				
Weight per Unit	2.82 oz [80 g]		2.96 oz [84 g]	
Packaging Dimensions (Single Unit)	2.8 x 1.2 x 1.2" [73 x 30 x 30 mm]			
Minimum Package Quantity	100 pieces			

inches
[mm]



In-line SPD for Coaxial & RF Systems

RayDat CP TV75 Series

C1 • C2 • C3



IEC/EN Category: C1/C2/C3
 Surge Discharge Ratings: I_n : 10 kA, I_{max} : 20 kA
 Max. Operating Voltage: 70, 180V
 Maximum Peak Power: 40, 125W
 Frequency Range: DC–2.0 GHz
 Impedance: 75 Ω
 Insertion Loss: < 0.4 dB
 Return Loss: > 20 dB
 Termination: TV Type (F-F, M-F)
 Housing: In-line Installation, Shielded Enclosure
 Compliance: IEC/EN 61643-21



Technical Data

CP TV75	70	180	
Electrical			
Maximum Continuous Operating Voltage	U_c	70V	180V
Maximum Peak Power	P_{max}	40W	125W
C2 Nominal Discharge Current (8/20 μ s)	I_n		10 kA
Maximum Discharge Current (8/20 μ s)	I_{max}		20 kA
Residual Voltage at (1 kV/ μ s)	U_{res}	< 600V	< 700V
Impedance	Z		75 Ω
Insertion Loss	I_L		< 0.4 dB
Return Loss	R_L		> 20 dB
Insulation Resistance of Protection	R_{iso}		> 10 G Ω
Frequency Range	f_G		0–2.0 GHz
Mechanical			
Temperature Range		-40 °F to +176 °F [-40 °C to +80 °C]	
Connection		TV Female/Female	TV Male/Female
Degree of Protection IEC/EN 60529		IP 20 (built-in)	
Housing Material		Metal	
Order Information			
Order Code	70	180	
CP TV75-FF-xx	800 879	800 880	
CP TV75-MF-xx	800 881	800 882	

RayDat CP TV75 Series

Internal Configuration

Legend
 GDT Gas Discharge Tube
 PE Ground

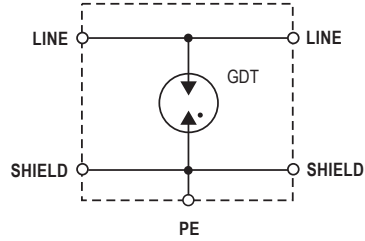

Dimensions & Packaging

CP TV75-FF

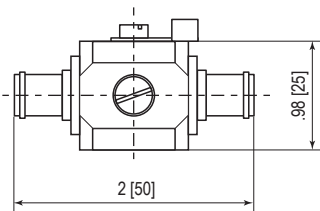

CP TV75-MF

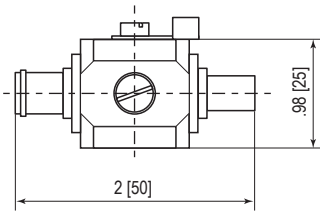

CP TV75	CP TV75-FF-xxx		CP TV75-MF-xxx	
	70	180	70	180
Dimensions				
Weight per Unit	2.82 oz [80g]		2.89 [82g]	
Packaging Dimensions (Single Unit)	2.8 x 1.2 x 1.2" [73 x 30 x 30mm]			
Minimum Package Quantity	100 pieces			

inches
[mm]



In-line SPD for Coaxial & RF Systems

RayDat CP-SMA Series

D1 • C1 • C2 • C3



IEC/EN Category: D1/C1/C2/C3
 Surge Discharge Ratings: I_n : 5 kA, I_{max} : 10 kA, I_{imp} : 1 kA
 Max. Operating Voltage: 180 V
 Maximum Peak Power: 125 W
 Frequency Range: DC–6 GHz
 Impedance: 50 Ω
 Insertion Loss: < 0.25 dB
 Return Loss: > 20 dB
 Termination: SMA Type (M-F)
 Housing: In-line Installation, Shielded Enclosure
 Compliance: IEC/EN 61643-21



Technical Data

CP-SMA

180

Electrical

Maximum Continuous Operating Voltage	U_c	180 V
Maximum Peak Power	P_{max}	125 W
C2 Nominal Discharge Current (8/20 μ s)	I_n	5 kA
Maximum Discharge Current (8/20 μ s)	I_{max}	10 kA
D1 Impulse Discharge Current (10/350 μ s)	I_{imp}	1 kA
Residual Voltage at (1 kV/ μ s)	U_{res}	1600 V
Impedance	Z	50 Ω
Insertion Loss	I_L	< 0.25 dB
Return Loss	R_L	> 20 dB
Insulation Resistance of Protection at U_c	R_{iso}	> 10 G Ω
Frequency Range	f_G	0 - 6.0 GHz

Mechanical

Temperature Range	-40 °C to +80 °C
Connection	SMA Male to SMA Female
Degree of Protection IEC/EN 60529	IP 20
Housing Material	Metal

Order Information

CP-SMA-MF-180	800 887
---------------	---------

RayDat CP-SMA Series

Internal Configuration

Legend
 GDT Gas Discharge Tube
 PE Ground

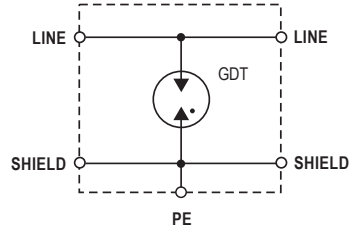

Dimensions & Packaging

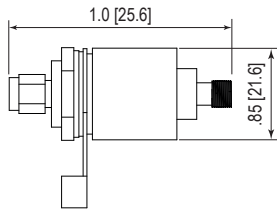

CP-SMA	180
Dimensions	
Weight per Unit	2.40 oz [68 g]
Packaging Dimensions (Single Unit)	20.84 × 1.58 × 1.58" [72 × 40 × 40 mm]
Minimum Package Quantity	100 pieces

inches
[mm]

RoHS
COMPLIANT  CE



Surge Protective Devices (SPDs)
for Power and Signal Lines

RayDat SUH-2-PS





Power and Signal Lines

Special features:

- Very high surge ratings
- The connection lines remain enabled during module replacement
- Protection of up to 2 signal lines and 1 power line
- Equipped with screw terminals



Symbol Legend:

-  DIN Rail Mounting
-  Screw Connect Terminals
-  Modular Design
-  Shield Directly Grounded

The RayDat SUH-2 PS Series has been developed to protect systems with one supply and one signal line (CAN bus, DeviceNet, etc.). This efficient overvoltage protective device is intended to protect lines from overvoltage surges and electrostatic discharges created by switching transients in buildings.

The signal line circuit is designed to minimize inter-capacitance, and shunt capacitance, thereby maximizing the operating frequency to 30 MHz. If the module is unplugged out of the base, the connection lines remain enabled.

SPD for DC Power Supply & Data

RayDat SUH-2 PS

D1 • C1 • C2 • C3



IEC/EN Category: D1/C1/C2/C3
 Surge Discharge Ratings: I_n : 10 kA, I_{max} : 20 kA, I_{imp} : 2.5 kA
 Voltages: 24V DC (Data Line)
 24V AC (Power Line)
 Frequency Range: 30 MHz
 Housing: Modular Design
 Compliance: IEC/EN 61643-21
 Configuration:

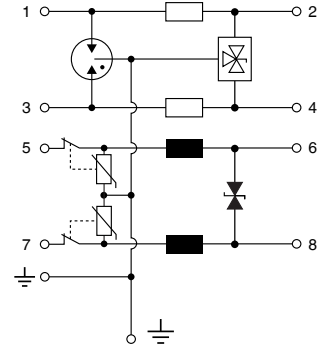

Technical Data

SUH-2 PS		Data Line	Power Supply Line
Electrical			
Lines Protected		2 (1 Data Line + 1 Power Supply Line)	
Nominal Operating Voltage (DC)	U_n	24V	24V AC/30V DC
Maximum Continuous Operating Voltage (DC)	U_c	28V	28V AC/40V DC
Rated Load Current at 25°C	I_L	1 A	3 A
C2 Nominal Discharge Current (8/20µs)	I_n		10 kA
Maximum Discharge Current (8/20µs)	I_{max}		20 kA
D1 Impulse Current (10/350µs)	I_{imp}	2.5 kA	-
Residual Voltage at 5kA (8/20µs)	U_{res}	< 70V	< 100V
Rated Spark Overvoltage	(Line-Ground)	31-37V	90-110V
	(Line-Line)	31-37V	42-52V
Response Time Overvoltage Protection	t_A		< 1 ns
Insulation Resistance of the Protection	R_{iso}	$\geq 28 M\Omega$	$\geq 40 M\Omega$
Serial Resistance per Path	R	1.6-2.0Ω	< 0.2Ω
Serial Inductivity	L		15 µH
Transverse Capacitance	C	50 pF	6.0 nF
Cut-off Frequency	f_G	30 MHz	1 kHz
Mechanical			
Temperature Range		-40 °F to +176 °F [-40 °C to +80 °C]	
Terminal Cross Section Multi-strand (max.)		12 AWG [4 mm ²]	
Terminal Screw Torque		4.5 lbf-in [0.5 Nm]	
Degree of Protection IEC/EN 60529		IP 20 (built-in)	
Housing Material		Thermoplastic; Grey; Extinguishing Degree V-0	
Mounting IEC/EN 60715		35mm DIN Rail	
Order Information			
Order Code		24	
SUH-2-xxPS		7086.81	
SUH-2-xxPSM (module)		7086.82	

RayDat SUH-2 PS

Internal Configuration

Legend

- BD Bi-directional TVS Diode
- DB Diode Block
- GDT Gas Discharge Tube
- L Inductor
- MOV Metal Oxide Varistor
- PG Protective Grounding
- R Resistor
- TC Thermo-clip
- TD Thermal Disconnecter

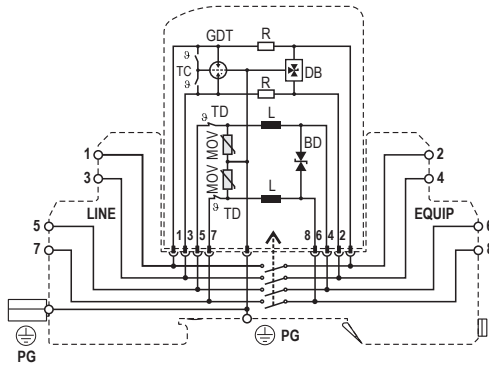

Dimensions & Packaging

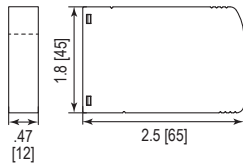
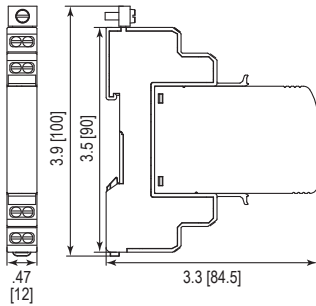

SUH-2-xxPS

24

Dimensions

Weight per Unit	2.53 oz [72 g]
Dimensions DIN 43880	2/3 TE
Packaging Dimensions (Single Unit)	3.4 x .59 x 4" [87 x 15 x 102 mm]
Minimum Package Quantity	15 pieces

SUH-2-xxPSM

24

Dimensions

Weight per Unit	1.19 oz [34 g]
Packaging Dimensions (Single Unit)	3.4 x .59 x 4" [87 x 15 x 102 mm]
Minimum Package Quantity	15 pieces

inches
[mm]



Modular & Compact Surge Protective Devices (SPDs) for DC Power Systems

DC Power Systems

Special features:





- Very high surge ratings
- Protects either floated or grounded lines
- Equipped with screw terminals
- High load current is provided (up to 7A)

RayDat SPLH*
RayDat PSC-2
ProTec DMDR 20**

*UL Listed
**UL Recognized



Symbol Legend:

-  DIN Rail Mounting
-  Screw Connect Terminals
-  Modular Design
-  Compact Design
-  Shield Directly Grounded

The RayDat SPLH-2 Series has been developed to protect ungrounded DC power supplies. Coarse protection is provided using two pole gas discharge tubes (GDT), while fine protection is provided using a high-speed silicon (SAD) stage. Care is taken to ensure coordination between these two stages without voltage or surge current blind spots occurring.

The RayDat PSC-2 Series is designed to protect power supplies. Coarse protection is provided by varistors (MOV), while fine protection is provided using a high-speed silicon (SAD) stage.

Internal thermal disconnectors are used to reduce the hazards of thermal runaway during fault conditions or mains incursion onto the low voltage data circuit. If the module is unplugged out of the base, the connection lines remain enabled.

The ProTec DMDR Series is designed to meet the unique requirements of protection for DC power systems found in telecom power and railway applications. The ProTec DMDR Series provides both, common and differential mode protection using high nominal discharge rating for extended operating life under DC conditions.

inches
[mm]

Compact Single-pole SPD
RayDat SPLH-2-7A
D1 • C1 • C2 • C3

UL Listed



IEC/EN Category: D1/C1/C2/C3
 Surge Discharge Ratings: I_n : 10kA, I_{imp} : 2.5kA
 Voltages: 36V DC
 Series Load Current: 7A
 Enclosure: DIN 43880 2TE, DIN Rail Mount
 Terminals: Stranded to 2.5 mm²
 Housing: Compact Design
 Compliance: IEC/EN 61643-21
 UL 497B 4th Edition



Technical Data

SPLH-2-7A

Electrical

Nominal Operating Voltage (DC)	U_n	36V
Maximum Continuous Operating Voltage (DC)	U_c	45V
Rated Load Current at 45°C	I_L	7A
Rated Load Current at 80°C	I_L	5A
C2 Nominal Discharge Current (8/20µs) (Line-Ground)	I_n	10kA
C2 Total Nominal Discharge Current (8/20µs)	I_n	20kA
D1 Impulse Current (10/350µs) (Line-Ground)	I_{imp}	2.5kA
D1 Total Impulse Current (10/350µs)	I_{imp}	5kA
Voltage Protection Level at C2 (8/20µs) (Line-Ground)	U_p	< 1000V
Voltage Protection Level at C2 (8/20µs) (Line-Line)	U_p	< 180V
Response Time Overvoltage Protection	t_A	< 1ns
Insulation Resistance of the Protection	R_{iso}	> 45MΩ
Serial Resistance per Path	R	< 1Ω
Serial Inductivity	L	22µH
Transverse Capacitance (Line-Ground)	C	15pF
Transverse Capacitance (Line-Line)	C	0.7nF

Mechanical & Environmental

Temperature Range	T_a	-40 °C to +80 °C
Terminal Screw Torque	M_{max}	0.5Nm
Conductor Cross Section		2.5mm ² (Solid, Stranded)
Mounting		35mm DIN Rail, EN 60715
Degree of Protection		IP 20
Housing Material		Thermoplastic: Extinguishing Degree UL 94 V-0

Order Information

Order Code		
SPLH-2-7A		127 626

RayDat SPLH-2-7A

Internal Configuration

Legend

- DB Diode Block
- GDT Gas Discharge Tube
- PG Protective Grounding
- L Inductor

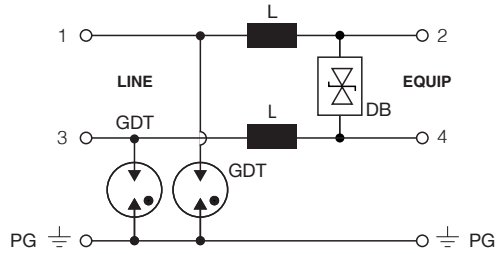

Dimensions & Packaging

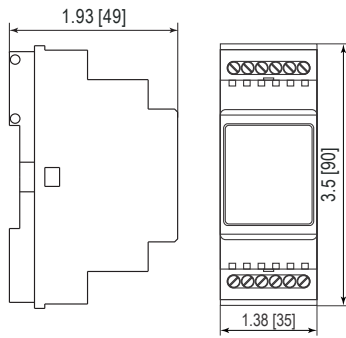

Dimensions & Packaging

SPLH-2-7A

Dimensions DIN 43880	2 TE
Single Unit Weight	3.17oz [90g]
Packaging Dimensions (Single Unit)	4.29 × 3.03 × 1.65" [109 × 77 × 42mm]
Minimum Order Quantity	7 Units

inches
[mm]



SPD for DC Power Systems with Low Residual Voltage

RayDat PSC-2 Series

C1 • C2 • C3



IEC/EN Category: C1/C2/C3
 Surge Discharge Ratings: I_n : 10 kA, I_{max} : 20 kA
 Voltages: 12, 24, 48 V DC
 Serial Inductivity: 10–14 μ H
 Housing: Modular Design
 Compliance: IEC/EN 61643-21
 Configuration:

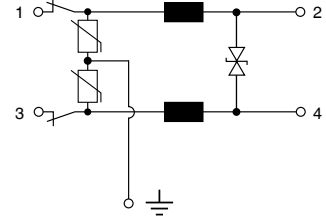

Technical Data

PSC-2 Series	12	24	48	
Electrical				
Lines Protected	1 (2 Conductors)			
Nominal Operating Voltage (DC)	U_n 12V	24V	48V	
Maximum Continuous Operating Voltage (DC)	U_c 15V	28V	52V	
Rated Operating Current at 25 °C	I_L	4 A		
C2 Nominal Discharge Current (8/20 μ s)	I_n	10 kA		
Maximum Discharge Current (8/20 μ s)	I_{max}	20 kA		
Residual Voltage at 5 kA (8/20 μ s)	U_{res}	< 32V	< 60V	< 135V
Rated Spark Overvoltage	(1, 3-PG)	90-110V	90-110V	90-110V
	(1, 3)	16-20V	30-36V	57-69V
Response Time Overvoltage Protection	t_A	< 1 ns		
Thermal Protection	Thermal Disconnection			
Insulation Resistance of the Protection	R_{iso}	$\geq 15 M\Omega$	$\geq 28 M\Omega$	$\geq 52 M\Omega$
Serial Inductance per Path	L	10–14 μ H		
Transverse Capacitance	C	< 5nF	< 3nF	< 1.5nF
Mechanical				
Temperature Range	-40 °F to +176 °F [-40 °C to +80 °C]			
Terminal Cross Section Multi-strand (max.)	12 AWG [4 mm ²]			
Terminal Screw Torque	4.5 lbf-in [0.5 Nm]			
Degree of Protection IEC/EN 60529	IP 20 (built-in)			
Housing Material	Thermoplastic; Grey; Extinguishing Degree V-0			
Mounting IEC/EN 60715	35mm DIN Rail			
Order Information				
Order Code	12	24	48	
PSC-2-xx	7086.83	7086.84	7086.85	
PSC-2-xxM (module)	7086.86	7086.87	7086.88	

RayDat PSC-2 Series

Internal Configuration

Legend

- BD Bi-Directional TVS Diode
- L Inductor
- MOV Metal Oxide Varistor
- PG Protective Ground
- TD Thermal Disconnecter

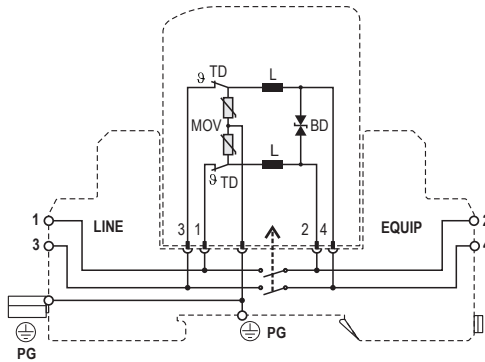

Dimensions & Packaging

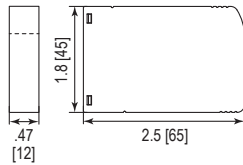
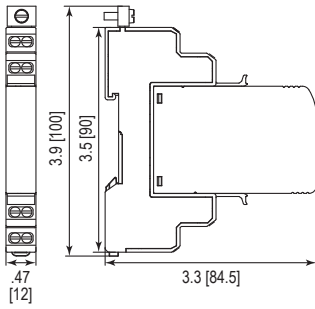

PSC-2 Series	12	24	48
Dimensions			
Weight per Unit	2.25 oz [64 g]		
Dimensions DIN 43880	2/3 TE		
Packaging Dimensions (Single Unit)	3.4 x .59 x 4" [87 x 15 x 102 mm]		
Minimum Package Quantity	15 pieces		

PSC-2-xxM	12	24	48
Dimensions			
Weight per Unit	1.26 oz [36 g]		
Packaging Dimensions (Single Unit)	3.4 x .59 x 4" [87 x 15 x 102 mm]		
Minimum Package Quantity	15 pieces		

inches
[mm]

SPD for DC Power Systems
ProTec DMDR 20 Series
 Class III • Type 3 • Type 4CA

UL Recognized



IEC/EN/UL Category: Class III/Type 3/Type 4CA
 Surge Discharge Ratings: U_{oc}/I_{cw} = up to 6kV/3kA
 I_{max} = up to 4kA (8/20 μ s)
 Protection Element: High Energy MOV and GDT
 Voltages: 24, 48, 60, 120V AC
 34, 60, 75, 150 V DC
 Status Indication: Remote Contacts + LED
 Housing: Modular Design
 Compliance: IEC 61643-11:2011
 EN 61643-11:2012+A11:2018
 UL 1449 5th Edition



Technical Data

ProTec DMDR 20 Series

24* 48 60 120

IEC Electrical

Nominal AC/DC Voltage	U_o	17V/17V	34V/48V	43V/60V	85V/120V
Maximum Continuous Operating Voltage (AC/DC)	U_c	24V/34V	48V/60V	60V/75V	120V/150V
Open Circuit Voltage of the Combination Wave Generator (1.2/50 μ s)	U_{oc}	2.4kV	2.4kV	6kV	6kV
Short Circuit Current of the Combination Wave Generator (8/20 μ s)	I_{cw}	1.2kA	1.2kA	3kA	3kA
Maximum Discharge Current (8/20 μ s)	I_{max}	2kA	2kA	4kA	4kA
Voltage Protection Level	(L - N) U_p	< 250V	< 500V	< 600V	< 1100V
	(L - PE)/(N - PE)	< 700V	< 800V	< 850V	< 1200V
Response Time of Overvoltage Protection	(L - N) t_A		< 25 ns		
	(L - PE)/(N - PE)		< 100 ns		
Overcurrent Protection (max)			32 A gG		
Short-Circuit Current Rating (AC)	I_{SCCR}		2 kA		
TOV Withstand 5s (AC)	U_T	115V	148V	163V	225V
Number of Ports				1	

UL Electrical

Maximum Continuous Operating Voltage (AC)	MCOV	24V	-	-	-
Maximum Continuous Operating Voltage (DC)	(+)-(-) V_{dcmcov}	34V			
	(+)-(-)(G)	17V			
Measured Limiting Voltage	(L - N)/(+)-(-) MLV	190V/230V	-	-	-
	(L/N - G)/(+)-(-)(G)	580V/540V	-	-	-
Nominal Discharge Current (8/20 μ s)	I_n	1 kA	-	-	-

Mechanical

Temperature Range	T_a	-40 °F to +185 °F [-40 °C to +85 °C]			
Permissible Humidity	RH	5%...95%			
Terminal Screw Torque	M_{max}	4.5 lbf-in [0.5Nm]			
Conductor Cross Section (max.)		10 AWG (Solid, Stranded) / 12 AWG (Flexible)			
		6 mm ² (Solid, Stranded) / 4 mm ² (Flexible)			
Mounting		35 mm DIN Rail, EN 60715			
Degree Of Protection		IP 20 (built-in)			
Housing Material		Thermoplastic: Extinguishing Degree UL 94 V-0			
Thermal Protection		Yes			
Operating Status Indication		Green LED			

Order Information

Order Code	24*	48	60	120
ProTec DMDR 20/xxx	510 783	510 833	510 834	510 835
ProTec DMDR 20/xxxM (module)	510 784	510 836	510 837	510 838

*UL Certification.

ProTec DMDR 20 Series

Internal Configuration

Legend

- GDT Gas Discharge Tube
- MOV Metal Oxide Varistor
- PE Ground
- R Resistor
- LED LED
- RC Remote Control (NC)

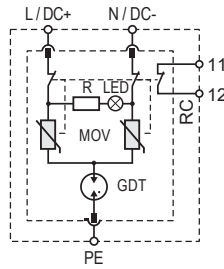

Dimensions & Packaging

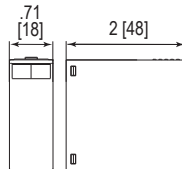
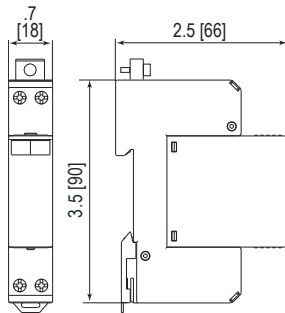

ProTec DMDR 20 Series	24	48	60	120
Dimensions				
Weight per Unit	3.38 oz [96g]			
Dimensions DIN 43880	1 TE			
Packaging Dimensions (Single Unit)	4.2 x 3 x .9" [109 x 77 x 24 mm]			
Minimum Package Quantity	12 pieces			

ProTec DMDR 20/xxx M	24	48	60	120
Dimensions				
Weight per Unit	1.12 oz [32g]			
Packaging Dimensions (Single Unit)	3.8 x 3 x 4.3" [98 x 77 x 110 mm]			
Minimum Package Quantity	12 pieces			

inches
[mm]

Regulatory Standards

1	IEC 61643-21:2012	Low voltage surge protective devices – Part 21: Surge protective devices connected to telecommunications and signaling networks – Performance requirements and testing methods
2	IEC 61643-22:2015	Low voltage surge protective devices – Part 21: Surge protective devices connected to telecommunications and signaling networks – Performance requirements and testing methods
3	IEC 61643-11:2011	Surge protective devices connected to low voltage power distribution systems – Requirements and test methods
4	IEC 61643-12:2020	Surge protective devices connected to low voltage power distribution systems – Selection and application principles
5	IEC 60364-5-53:2019	Electrical installation of buildings – Part 5-53: Selection and erection of electrical equipment-isolation, switching and control
6	IEC 61000-4-5:2017	Electromagnetic compatibility (EMC) – Part 4-5: Testing and measurement techniques – Surge immunity test
7	IEC 62305-1:2010	Protection against lightning – Part 1: General principles
8	IEC 62305-2:2010	Protection against lightning – Part 2: Risk management
9	IEC 62305-3:2010	Protection against lightning – Part 3: Physical damage to structures and life hazard
10	IEC 62305-4:2010	Protection against lightning – Part 4: Electrical and electronic systems within structures
11	ITU-T K.20:2019	Resistibility of telecommunication equipment installed in a telecommunications center to overvoltages and overcurrents
12	ITU-T K.21:2019	Resistibility of telecommunication equipment installed in customer premises to overvoltages and overcurrents
13	ITU-T K.44:2019	Resistibility tests for telecommunication equipment exposed to overvoltages and overcurrents – Basic Recommendation
14	IEC 60099-4:2014	Surge arresters – Part 4: Metal-oxide surge arresters without gaps for AC systems
15	IEC 60099-5:2018	Surge arresters – Part 5: Selection and application recommendations
16	IEC PAS 60099-7:2004	Surge arresters – Part 7: Glossary of terms and definitions from IEC publications 60099-1, 60099-4, 60099-6, 61643-11, 61643-12, 61643-21, 61643-311, 61643-321, 61643-331 and 61643-341
17	IEC 60038:2009	IEC standard voltages
18	UL 497B 4th Edition	Protectors for Data Communications and Fire-Alarm Circuits
19	IEC 62497-2:2010	Railway applications – Insulation coordination – Part 2: Overvoltages and related protection
20	EN 50526-1:2012	Railway applications – Fixed installations – DC surge arresters and voltage limiting devices – Part 1: Surge arresters
21	EN 50123-5:2003	Railway applications – Fixed installations – DC switchgear – Part 5: Surge arresters and low-voltage limiters for specific use in DC systems
22	EN 50122-1:2017	Railway applications – Fixed installations – Part 1: Protective provisions relating to electrical safety and earthing
23	IEC 60364-7-712:2002	Electrical installations of buildings – Part 7-712: Requirements for special installations or locations – Solar photovoltaic (PV) power supply systems
24	HD 60364-7-712:2016	Electrical installations of buildings – Part 7-712: Requirements for special installations or locations – Solar photovoltaic (PV) power supply systems
25	EN 61173:2001	Overvoltage protection for photovoltaic (PV) power generating systems – guide 32. SIST EN 61400-1:2006/A1:2011 Wind turbines – Part 1: Design requirements (IEC 61400-1:2005/A1:2010)
26	IEC 61400-24:2019	Wind turbine generator systems – Part 24: Lightning protection
27	EN 50539-12:2014	Low-voltage surge protective devices – Surge protective devices for specific application including DC – Part 12: Selection and application principles – SPDs connected to photovoltaic installations
28	EN 50539-11:2012	Low-voltage surge protective devices – Surge protective devices for specific application including DC – Part 11: Requirements and tests for SPDs in photovoltaic applications
29	IEEE 802.3-2018	IEEE standard for Ethernet

References

Selection Table for Recommended Surge Protective Devices (SPDs)

Recommended SPDs for use in zone interfaces according to IEC 62305-1 and IEC 61000-4-5, based on correlation between standards IEC 61643-11 and IEC 61643-21.

Lightning Protection Zones	Test Class of SPD to IEC 61643-11	Category of SPD to IEC 61643-21
0/1	Test Class 1	D1
1/2	Test Class 2	C2
2/3	Test Class 3	C1

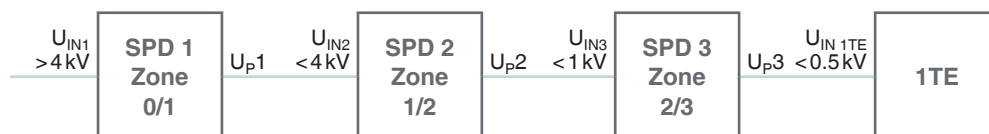

Typical Components Used in SPDs Voltage-limiting and Current Limiting Devices

Voltage-clamping Devices



Varistor (MOV)

A varistor is a bipolar, non-linear resistor with symmetrical voltage-current characteristics, where the resistance decreases with increasing characteristic curve.



Transient Voltage Suppression (TVS) Diode

A TVS diode is a clamping device that limits voltage spikes by the low impedance avalanche breakdown of the P/N junction. TVS diode contains a P/N junction similar to a Zener diode but with a larger cross section, which is proportional to its surge power rating. TVS diode has a very short response time, making it suitable for limiting fast rising transient voltages.

Voltage-switching Devices



Gas Discharge Tube (GDT)

A GDT is an arrangement of electrodes in a gas within an insulating, temperature-resistant ceramic or glass cylinder. Because of their switching characteristic and rugged construction, GDTs exceed other components in current carrying capability.



Thyristor Surge Suppressor (TSS) Fixed Voltage Types

A Thyristor surge suppressor is voltage-switching device, when above a certain breakdown current, the NPNP structure regenerates and switches to a low voltage condition. The multiple PN junctions of the TSS reduce the overall capacitance.

Current Limiting Devices



Positive Temperature Coefficient Resistor (PTC Resistor)

PTC resistors are ceramic components whose electrical resistance rapidly increases when a certain temperature is exceeded. An overcurrent condition causes the devices to increase their resistance, thus reducing current flow.



Common Terminology

1.2/50 μ s Voltage Impulse

Voltage impulse with a nominal virtual front time of 1.2 μ s and a nominal time to half-value of 50 μ s.

8/20 μ s Current Impulse

Current impulse with a nominal virtual front time of 8 μ s and a nominal time to half-value of 20 μ s.

American Wire Gauge (AWG)

American Wire Gauge (AWG) is a standardized wire gauge system for the diameters of round, solid, nonferrous, electrically conducting wire. The larger the AWG number or wire gauge, the smaller the physical size of the wire. The smallest AWG size is 40 and the largest is 000 (4/0).

Combination Wave

The combination wave is delivered by a generator that applies a 1.2/50 μ s voltage impulse across an open circuit and an 8/20 μ s current impulse into a short circuit. The voltage, current amplitude and waveforms that are delivered to the SPD are determined by the generator impedance and the impedance of the SPD to which the surge is applied. The short-circuit current is symbolized by I_{sc} . The open-circuit voltage is symbolized by U_{oc} .

Environmental Protection Provided by Enclosure--Ingress Protection Rating (IP)

The extent of protection provided by an enclosure against access to hazardous parts, against ingress of solid foreign objects and/or against ingress of water per IEC 60529.

Impulse Discharge Current I_{imp} (10/350 μ s Current Impulse)

The crest value of a discharge current through SPD with specified charge transfer Q and specified energy W/R in a specified time.

Maximum Continuous Operating Voltages (U_c or MCOV)

The maximum root-mean square (RMS) or DC voltage, which may be continuously applied to the SPD's mode of protection.

Maximum Discharge Current I_{max}

Crest value of a current through the SPD having an 8/20 μ s waveshape and magnitude according to the manufacturers specifications: I_{max} is greater than I_n .

Metal Oxide Varistor (MOV)

A varistor is a bipolar, non-linear resistor with a symmetrical voltage current characteristic, where the resistance decreases with an increasing characteristic curve.

Multi-pole Surge Protective Device (SPD)

Type of SPD with more than one mode of protection, or a combination of electrically interconnected SPDs offered as a unit.

Nominal AC Voltage U_o/U_n

In TN and TT Systems: Nominal RMS AC line voltage to earth; in IT Systems: Nominal AC voltage between line conductor and neutral conductor or midpoint conductor.

Overcurrent Protection

Overcurrent device such as a circuit-breaker or fuse, which could be part of the electrical installation located externally upstream of the SPD.

Residual Voltage U_{res}

The crest value of voltage that appears between the terminals of an SPD due to the passage of discharge current.

SPD Disconnecter

Internal build-in external device required for disconnecting an SPD or part of an SPD from the power system.

Surge Protective Device (SPD)

A device that is intended to limit surge overvoltages and divert surge currents. It contains at least one nonlinear component.







Total Discharge Current I_{Total}





Current which flows through earth conductor of a multi-pole SPD during the total discharge current test.

Voltage Protection Level U_p

Maximum voltage to be expected at the SPD terminals due to an impulse stress with defined voltage steepness and impulse stress with a discharge current, given amplitude and waveshape.

Product Index

	Product Name	Order Code	Dimensions DIN 43880	Page	
D1 • C1 • C2 • C3 Analogue Systems Modular SPDs for Data & Signal Lines					
	RayDat SLH-2-5	7086.33	2/3TE	22	
	RayDat SLH-2-12	7086.34	2/3TE	22	
	RayDat SLH-2-15	7086.35	2/3TE	22	
	RayDat SLH-2-24	7086.36	2/3TE	22	
	RayDat SLH-2-30	7082.80	2/3TE	22	
	RayDat SLH-2-48	7086.37	2/3TE	22	
	RayDat SLH-2-60	7086.38	2/3TE	22	
	RayDat SLH-2-110	7086.39	2/3TE	76	
	RayDat SLH-2-5M	7086.40	2/3TE	22	
	RayDat SLH-2-12M	7086.41	2/3TE	22	
RayDat SLH-2-15M	7086.42	2/3TE	22		
RayDat SLH-2-24M	7086.43	2/3TE	22		
RayDat SLH-2-30M	7082.81	2/3TE	22		
RayDat SLH-2-48M	7086.44	2/3TE	22		
RayDat SLH-2-60M	7086.45	2/3TE	22		
RayDat SLH-2-110M	7086.46	2/3TE	76		
	RayDat SLH-2-5Q	7085.05	2/3TE	22	
	RayDat SLH-2-12Q	7085.06	2/3TE	22	
	RayDat SLH-2-15Q	7085.07	2/3TE	22	
	RayDat SLH-2-24Q	7085.08	2/3TE	22	
	RayDat SLH-2-30Q	7085.09	2/3TE	22	
	RayDat SLH-2-48Q	7085.10	2/3TE	22	
	RayDat SLH-2-60Q	7085.11	2/3TE	22	
	RayDat SLH-2-110Q	7085.12	2/3TE	76	
		RayDat SLH-4-5	7086.47	2/3TE	24
		RayDat SLH-4-12	7086.48	2/3TE	24
RayDat SLH-4-15		7086.49	2/3TE	24	
RayDat SLH-4-24		7086.50	2/3TE	24	
RayDat SLH-4-30		7082.78	2/3TE	24	
RayDat SLH-4-48		7086.51	2/3TE	24	
RayDat SLH-4-60		7086.52	2/3TE	24	
RayDat SLH-4-110		7086.53	2/3TE	78	
RayDat SLH-4-5M		7086.54	2/3TE	24	
RayDat SLH-4-12M		7086.55	2/3TE	24	
RayDat SLH-4-15M	7086.56	2/3TE	24		
RayDat SLH-4-24M	7086.57	2/3TE	24		
RayDat SLH-4-30M	7082.79	2/3TE	24		
RayDat SLH-4-48M	7086.58	2/3TE	24		
RayDat SLH-4-60M	7086.59	2/3TE	24		
RayDat SLH-4-110M	7086.60	2/3TE	78		
	RayDat SLH-4-5Q	7085.13	2/3TE	24	
	RayDat SLH-4-12Q	7085.14	2/3TE	24	
	RayDat SLH-4-15Q	7085.15	2/3TE	24	
	RayDat SLH-4-24Q	7085.16	2/3TE	24	
	RayDat SLH-4-30Q	7085.17	2/3TE	24	
	RayDat SLH-4-48Q	7085.18	2/3TE	24	
	RayDat SLH-4-60Q	7085.19	2/3TE	24	
	RayDat SLH-4-110Q	7085.20	2/3TE	78	
		RayDat SPH-2-30	7082.84	2/3TE	34
		RayDat SPH-2-230	7081.06	2/3TE	74
RayDat SPH-2-30M		7082.85	2/3TE	34	
RayDat SPH-2-230M		7081.08	2/3TE	74	
RayDat SPH-2-30Q		7085.25	2/3TE	34	
RayDat SPH-2-230Q		7085.26	2/3TE	74	
	RayDat SPH-4-30	7082.82	2/3TE	36	
	RayDat SPH-4-30/0	7086.89	2/3TE	36	
	RayDat SPH-4-30M	7082.83	2/3TE	36	
	RayDat SPH-4-30/0M	7085.29	2/3TE	36	
	RayDat SPH-4-30Q	7085.24	2/3TE	36	
	RayDat SPH-4-30/Q	7085.28	2/3TE	36	

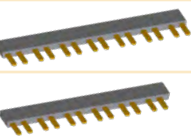
	Product Name	Order Code	Dimensions DIN 43880	Page
D1 • C1 • C2 • C3 Analogue Systems Modular SPDs for Data & Signal Lines				
	RayDat SPI-2-30	7085.67	2/3TE	38
	RayDat SPI-2-30M	7085.68	2/3TE	38
	RayDat SPI-4-30	7085.69	2/3TE	40
	RayDat SPI-4-30M	7085.70	2/3TE	40
	RayDat SRH-2-5	7086.17	2/3TE	44
	RayDat SRH-2-12	7086.18	2/3TE	44
	RayDat SRH-2-15	7086.19	2/3TE	44
	RayDat SRH-2-24	7086.20	2/3TE	44
	RayDat SRH-2-30	7086.21	2/3TE	44
	RayDat SRH-2-48	7086.22	2/3TE	44
	RayDat SRH-2-60	7086.23	2/3TE	44
	RayDat SRH-2-110	7086.24	2/3TE	82
	RayDat SRH-2-5M	7086.25	2/3TE	44
	RayDat SRH-2-12M	7086.26	2/3TE	44
	RayDat SRH-2-15M	7086.27	2/3TE	44
	RayDat SRH-2-24M	7086.28	2/3TE	44
	RayDat SRH-2-30M	7086.29	2/3TE	44
	RayDat SRH-2-48M	7086.30	2/3TE	44
	RayDat SRH-2-60M	7086.31	2/3TE	44
	RayDat SRH-2-110M	7086.32	2/3TE	82
	RayDat SRH-2-5Q	7085.33	2/3TE	44
	RayDat SRH-2-12Q	7085.34	2/3TE	44
	RayDat SRH-2-15Q	7085.35	2/3TE	44
	RayDat SRH-2-24Q	7085.36	2/3TE	44
RayDat SRH-2-30Q	7085.37	2/3TE	44	
RayDat SRH-2-48Q	7085.38	2/3TE	44	
RayDat SRH-2-60Q	7085.39	2/3TE	44	
RayDat SRH-2-110Q	7085.40	2/3TE	82	
	RayDat SRH-2-5-L	7085.44	2/3TE	46
	RayDat SRH-2-12-L	7085.46	2/3TE	46
	RayDat SRH-2-24-L	7085.48	2/3TE	46
	RayDat SRH-2-30-L	7085.42	2/3TE	46
	RayDat SRH-2-5-LM	7085.45	2/3TE	46
	RayDat SRH-2-12-LM	7085.47	2/3TE	46
	RayDat SRH-2-24-LM	7085.49	2/3TE	46
	RayDat SRH-2-30-LM	7085.43	2/3TE	46
	RayDat SRH-2-5-LQ	7085.56	2/3TE	46
	RayDat SRH-2-12-LQ	7085.58	2/3TE	46
	RayDat SRH-2-24-LQ	7085.60	2/3TE	46
	RayDat SRH-2-30-LQ	7085.62	2/3TE	46
RayDat SRH-2L Accessories				
	RayDat PSU-14	127 621	2/3TE	48
	RayDat PSU-PB-7P	127 622	2/3TE	48
	RayDat PSU-PB-6P	127 623	2/3TE	48

	Product Name	Order Code	Dimensions DIN 43880	Page	
D1 • C1 • C2 • C3 Analogue Systems Modular SPDs for Data & Signal Lines					
<i>-continued</i>					
	RayDat SSH-3-5	7086.01	2/3TE	26	
	RayDat SSH-3-12	7086.02	2/3TE	26	
	RayDat SSH-3-15	7086.03	2/3TE	26	
	RayDat SSH-3-24	7086.04	2/3TE	26	
	RayDat SSH-3-30	7086.05	2/3TE	26	
	RayDat SSH-3-48	7086.06	2/3TE	26	
	RayDat SSH-3-60	7086.07	2/3TE	26	
	RayDat SSH-3-5M	7086.09	2/3TE	26	
	RayDat SSH-3-12M	7086.10	2/3TE	26	
	RayDat SSH-3-15M	7086.11	2/3TE	26	
	RayDat SSH-3-24M	7086.12	2/3TE	26	
	RayDat SSH-3-30M	7086.13	2/3TE	26	
	RayDat SSH-3-48M	7086.14	2/3TE	26	
	RayDat SSH-3-60M	7086.15	2/3TE	26	
	RayDat SSH-3-5Q	7086.90	2/3TE	26	
	RayDat SSH-3-12Q	7086.91	2/3TE	26	
	RayDat SSH-3-15Q	7086.92	2/3TE	26	
	RayDat SSH-3-24Q	7086.93	2/3TE	26	
	RayDat SSH-3-30Q	7086.94	2/3TE	26	
	RayDat SSH-3-48Q	7086.95	2/3TE	26	
	RayDat SSH-3-60Q	7086.96	2/3TE	26	
	RayDat SUI-4-5	7083.21	2/3TE	30	
	RayDat SUI-4-12	7083.22	2/3TE	30	
	RayDat SUI-4-15	7083.23	2/3TE	30	
	RayDat SUI-4-24	7083.24	2/3TE	30	
	RayDat SUI-4-30	7083.25	2/3TE	30	
	RayDat SUI-4-48	7083.26	2/3TE	30	
	RayDat SUI-4-60	7083.27	2/3TE	30	
	RayDat SUI-4-110	7083.28	2/3TE	80	
	RayDat SUI-4-5M	7083.29	2/3TE	30	
	RayDat SUI-4-12M	7083.30	2/3TE	30	
	RayDat SUI-4-15M	7083.31	2/3TE	30	
	RayDat SUI-4-24M	7083.32	2/3TE	30	
	RayDat SUI-4-30M	7083.33	2/3TE	30	
	RayDat SUI-4-48M	7083.34	2/3TE	30	
	RayDat SUI-4-60M	7083.35	2/3TE	30	
	RayDat SUI-4-110M	7083.36	2/3TE	80	
	D1 • C1 • C2 • C3 Analogue Systems SPDs for Explosive Environments				
		RayDat Ex-2-12V	704 120	1TE	50
		RayDat Ex-2-24V	704 121	1TE	50
		RayDat PLP-24Ex 1/2" NPT	127 594		52
		RayDat PLP-24Ex M20x1.5	127 595		52
RayDat PLP-24Ex G 1/2"		127 596		52	
RayDat PLP2-24Ex 1/2" NPT		127 600		52	
RayDat PLP2-24Ex M20x1.5		127 601		52	
RayDat PLP2-24Ex G 1/2"		127 602		52	
RayDat PLP2-48 Ex 1/2" NPT		127 597		52	
RayDat PLP2-48 Ex M20x1.5		127 598		52	
RayDat PLP2-48 Ex G 1/2"		127 599		52	
RayDat PLP-24/5 Ex 1/2" NPT		127 603		52	
RayDat PLP-24/5 Ex M20x1.5		127 604		52	
RayDat PLP-24/5 Ex G 1/2"		127 605		52	
RayDat PLP3L-24Ex 1/2" NPT		127 606		52	
RayDat PLP3L-24Ex M20x1.5		127 607		52	
RayDat PLP3L-24Ex G 1/2"		127 608		52	

	Product Name	Order Code	Dimensions DIN 43880	Page
--	--------------	------------	-------------------------	------

C1 • C3 Analogue Systems Modular SPDs for Data & Signal Lines



RayDat SLL-4-30	7082.92	2/3TE	28
RayDat SLL-4-30M	7082.93	2/3TE	28
RayDat SLL-4-30Q	7085.27	2/3TE	28

D1 • C1 • C2 • C3 Digital Systems Modular & Compact SPDs for Bus System Data & Signal Lines



RayDat SBH-3-5	7082.86	2/3TE	60
RayDat SBH-3-12	7082.88	2/3TE	60
RayDat SBH-3-30	7082.90	2/3TE	60
RayDat SBH-3-5M	7082.87	2/3TE	60
RayDat SBH-3-12M	7082.89	2/3TE	60
RayDat SBH-3-30M	7082.91	2/3TE	60
RayDat SBH-3-5Q	7085.21	2/3TE	60
RayDat SBH-3-12Q	7085.22	2/3TE	60
RayDat SBH-3-30Q	7085.23	2/3TE	60



RayDat SGH-3-5	7086.61	2/3TE	62
RayDat SGH-3-12	7086.62	2/3TE	62
RayDat SGH-3-15	7086.63	2/3TE	62
RayDat SGH-3-24	7086.64	2/3TE	62
RayDat SGH-3-30	7086.65	2/3TE	62
RayDat SGH-3-48	7086.66	2/3TE	62
RayDat SGH-3-60	7086.67	2/3TE	62
RayDat SGH-3-110	7086.68	2/3TE	84
RayDat SGH-3-5M	7086.69	2/3TE	62
RayDat SGH-3-12M	7086.70	2/3TE	62
RayDat SGH-3-15M	7086.71	2/3TE	62
RayDat SGH-3-24M	7086.72	2/3TE	62
RayDat SGH-3-30M	7086.73	2/3TE	62
RayDat SGH-3-48M	7086.74	2/3TE	62
RayDat SGH-3-60M	7086.75	2/3TE	62
RayDat SGH-3-110M	7086.76	2/3TE	84
RayDat RS 485	703 812	2TE	64



D1 • C1 • C2 • C3 Digital Systems SPDs for Bus System Data & Signal Lines

















RayDat KNX	127 649		66
------------	---------	--	----



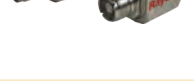

D1 • C1 • C2 • C3 Digital Systems SPDs for Local Area Network Data & Signal Lines



RayDat NET 6 POE	706 312		56
------------------	---------	--	----

	Product Name	Order Code	Dimensions DIN 43880	Page
	RayDat SGH-3-110	7086.68	2/3TE	84
	RayDat SGH-3-110M	7086.76	2/3TE	84
	RayDat SLH-2-110	7086.39	2/3TE	76
	RayDat SLH-2-110M	7086.46	2/3TE	76
	RayDat SLH-2-110Q	7085.12	2/3TE	76
	RayDat SLH-4-110	7086.53	2/3TE	78
	RayDat SLH-4-110M	7086.60	2/3TE	78
	RayDat SLH-4-110Q	7085.20	2/3TE	78
	RayDat SPH-2-230	7081.06	2/3TE	74
	RayDat SPH-2-230M	7081.08	2/3TE	74
	RayDat SPH-2-230Q	7085.26	2/3TE	74
	RayDat SRH-2-110	7086.24	2/3TE	82
	RayDat SRH-2-110M	7086.32	2/3TE	82
	RayDat SRH-2-110Q	7085.40	2/3TE	82
	RayDat SUI-4-110	7083.28	2/3TE	80
	RayDat SUI-4-110M	7083.36	2/3TE	80
	RayTel 10	124 150		70
	RayTel 20	124 152		72

	Product Name	Order Code	Dimensions DIN 43880	Page
	RayCox BNC 5	7050.22		88
	RayCox BNC 12	7050.13		88
	RayCox IEC 48	125 093		90
	RayCox F48	125 094		90
	RayDat CP BNC-FF-70	800 850		92
	RayDat CP BNC-FF-180	800 851		92
	RayDat CP BNC-FF-280	800 852		92
	RayDat CP BNC-MF-70	800 853		92
	RayDat CP BNC-MF-180	800 854		92
	RayDat CP BNC-MF-280	800 855		92
	RayDat CP 7/16-MF-70	800 856		94
	RayDat CP 7/16-MF-180	800 857		94
	RayDat CP 7/16-MF-280	800 858		94
	RayDat CP N-FF-70	800 859		96
	RayDat CP N-FF-180	800 860		96
	RayDat CP N-FF-280	800 861		96
	RayDat CP N-MF-70	800 862		96
	RayDat CP N-MF-180	800 863		96
	RayDat CP N-MF-280	800 864		96
	RayDat CP N-6G-FF-180	800 865		98
	RayDat CP N-6G-MF-180	800 866		98
	RayDat CP TNC-6G-FF-180	800 867		100
	RayDat CP TNC-6G-MF-180	800 868		100
	RayDat CP UHF-FF-70	800 869		102
	RayDat CP UHF-FF-180	800 870		102
	RayDat CP UHF-FF-280	800 871		102
	RayDat CP UHF-MF-70	800 872		102
	RayDat CP UHF-MF-180	800 873		102
	RayDat CP UHF-MF-280	800 874		102
	RayDat CP F75-FF-70	800 875		104
	RayDat CP F75-FF-180	800 876		104
	RayDat CP F75-MF-70	800 877		104
	RayDat CP F75-MF-180	800 878		104
	RayDat CP TV75-FF-70	800 879		106
	RayDat CP TV75-FF-180	800 880		106
	RayDat CP TV75-MF-70	800 881		106
	RayDat CP TV75-MF-180	800 882		106
	RayDat CP-SMA	800 887		108

	Product Name	Order Code	Dimensions DIN 43880	Page
D1 • C1 • C2 • C3 Modular SPDS for Power & Signal Lines				
	RayDat SUH-2-30PS	7086.81	2/3TE	112
	RayDat SUH-2-30PSM	7086.82	2/3TE	112
Class III • D1 • C1 • C2 • C3 Modular & Compact SPDs for DC Power Systems				
	ProTec DMDR 20/24V	510 783	1TE	120
	ProTec DMDR 20/48V	510 833	1TE	120
	ProTec DMDR 20/60V	510 834	1TE	120
	ProTec DMDR 20/120V	510 835	1TE	120
	Module ProTec DMDR 20/24V	510 784	1TE	120
	Module ProTec DMDR 20/48V	510 836	1TE	120
	Module ProTec DMDR 20/60V	510 837	1TE	120
	Module ProTec DMDR 20/120V	510 838	1TE	120
	RayDat PSC-2-12	7086.83	2/3TE	118
	RayDat PSC-2-24	7086.84	2/3TE	118
	RayDat PSC-2-48	7086.85	2/3TE	118
	RayDat PSC-2-12M	7086.86	2/3TE	118
	RayDat PSC-2-24M	7086.87	2/3TE	118
	RayDat PSC-2-48M	7086.88	2/3TE	118
	RayDat SPLH-2-7A	127 626	2TE	116



Raycap reserves the right to introduce changes in performance, dimensions and materials in the course of technical progress. No part of this work, nor of the information laid down herein and or derivable here from and/ or developed in connection here with, may be reproduced or used in any form or by any means. Legal action will be taken against infringements. This publication replaces previous editions and is subject to change at any time.

©2021 Raycap All rights reserved.

Raycap Worldwide Locations



Raycap Inc.
806 South Clearwater Loop
Post Falls, ID 83854
United States of America

7555-A Palmetto Commerce Pkwy
North Charleston, SC 29420
United States of America

46 Sellers Street
Kearny, NJ 07032
United States of America

Raycap GmbH
Parkring 11
85748 Garching Munich
Germany

Raycap S.A.
Telou & Petroutsou 14
15124 Maroussi Athens
Greece

Raycap S.A. Manufacturing
Industrial Area of Drama
66100 Drama
Greece

Raycap d.o.o.
Poslovna cona Žeje pri Komendi
Pod hrasti 7
1218 Komenda
Slovenia

Raycap Cyprus Ltd.
46 Lefkosias Street
Industrial Area of Dali
2540 Nicosia
Cyprus

Raycap SAS
84 rue Charles Michels
Building B
93200 Saint-Denis
France

Raycap Corporation SRL
102, Barbu Vacarescu
entrance D, 4th floor, D22,
020283 Bucharest
Romania

Raycap (Suzhou) Co. Ltd.
Block B, Phase II
of New Sea Union
No. 58 Heshun Road
SIP, Suzhou 215122
Jiangsu Province
China



Raycap

raycap.com info@raycap.com

©2024 Raycap All rights reserved.
G29-01-001 240425