

DATA SHEET

SPD with Remote Contacts RayDat SRH-2-110 D1 • C1 • C2 • C3

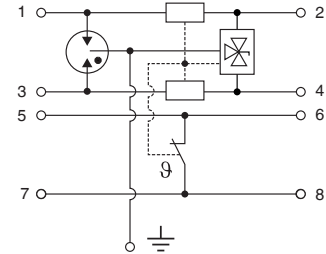

IEC/EN Category: D1/C1/C2/C3
 Surge Discharge Ratings: I_n : 10 kA, I_{max} : 20 kA, I_{imp} : 2.5 kA
 Voltages: 110V DC
 Frequency Range: 30 MHz
 Housing: Modular Design
 Compliance: IEC/EN 61643-21
 Configuration:



Technical Data

SRH-2-xxx

110

Electrical

Lines Protected		1 (2 Conductors)
Nominal Operating Voltage (DC)	U_n	110V
Maximum Continuous Operating Voltage (DC)	U_c	170V
Rated Load Current at 25°C	I_L	1 A
C2 Nominal Discharge Current (8/20 μs)	I_n	10 kA
Maximum Discharge Current (8/20 μs)	I_{max}	20 kA
D1 Impulse Current (10/350 μs)	I_{imp}	2.5 kA
Residual Voltage at 5 kA (8/20 μs)	U_{res}	< 450V
Rated Spark Overvoltage	(Line-Ground)	184-264V
	(Line-Line)	184-264V
Response Time Overvoltage Protection	t_A	< 1 ns
Thermal Protection		Yes
Insulation Resistance of the Protection	R_{iso}	≥ 170 MΩ
Serial Resistance per Path	R	1.6-2.0 Ω
Transverse Capacitance	C	50 pF
Cut-off Frequency	f_G	30 MHz

Mechanical

Temperature Range		-40 °F to +176 °F [-40 °C to +80 °C]
Terminal Cross Section Multi-strand (max.)		12 AWG [4 mm ² , 2.5 mm ² Q Version]
Terminal Screw Torque		4.5 lbf-in [0.5 Nm]
Degree of Protection IEC/EN 60529		IP 20 (built-in)
Housing Material		Thermoplastic; Grey; Extinguishing Degree V-0
Mounting IEC/EN 60715		35 mm DIN Rail
Remote Contacts Ratings		AC 250V/0.5 A, DC 50V/1 A

Order Information

Order Code		110
SRH-2-xxx		7086.24
SRH-2-xxxQ (Quick Connect Terminals)		7085.40
SRH-2-xxxM (module)		7086.32

RayDat SRH-2-110

Internal Configuration

Legend

- DB Diode Block
- GDT Gas Discharge Tube
- PG Protective Grounding
- R Resistor
- RC Remote Control (NC)
- TC Thermo-clip

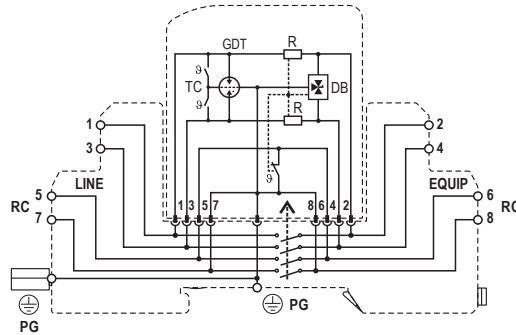

Dimensions & Packaging

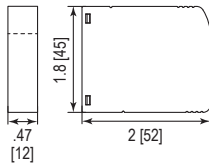
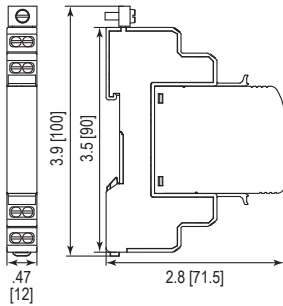

SRH-2-xxx	110
Dimensions	
Weight per Unit	2.04 oz [58 g]
Dimensions DIN 43880	2/3 TE
Packaging Dimensions (Single Unit)	3.4 x .59 x 4" [87 x 15 x 102 mm]
Minimum Package Quantity	15 pieces

SRH-2-xxxM Series	110
Dimensions	
Weight per Unit	.84 oz [24 g]
Packaging Dimensions (Single Unit)	3.4 x .59 x 4" [87 x 15 x 102 mm]
Minimum Package Quantity	15 pieces

Quick Connect Terminals

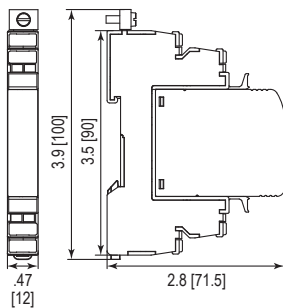

SRH-2-xxxQ Series	110
Dimensions	
Weight per Unit	2.11 oz [60 g]
Dimensions DIN 43880	2/3 TE
Packaging Dimensions (Single Unit)	3.4 x .59 x 4" [87 x 15 x 102 mm]
Minimum Package Quantity	15 pieces

inches
[mm]

Information contained in this document is subject to change at any time without notice.

